

REVISED 7/25/2017

ITEMS REQUIRED:	SMALL FLAT BLADED SCREWDRIVER	CENTER PUNCH
	#2 MEDIUM PHILLIPS SCREWDRIVER	HAMMER
	8MM WRENCH	WATER PROOF SEALANT
	7/16" DRILL BIT & ELECTRICAL DRILL	ELECTRICAL TAPE

NOTE: TO ASSURE THAT THIS LIGHT WAS NOT ABUSED IN SHIPMENT WE RECOMMEND TESTING THE LIGHT BEFORE INSTALLATION.

NOTE: REPLACEMENT BULB IS BBP PART NUMBER 10-282

INSTALLATION:

1. REMOVE THE FOLLOWING:

A. USING THE SMALL FLAT BLADED SCREWDRIVER, PRY OFF THE SIDE AND REAR SNAP ON TRIM COVER PIECES (1A) FROM THE LOWER LEFT AND RIGHT HAND SADDLEBAG CORNER COVERS (1B).

B. USING THE #2 MEDIUM PHILLIPS SCREWDRIVER, REMOVE THE SIDE AND REAR PHILLIPS SCREWS (1C) AND THE LOWER LEFT AND RIGHT HAND SADDLEBAG CORNER COVERS (1B).

C. OPEN THE LEFT AND RIGHT HAND SADDLEBAG DOOR PANELS (1D) AND USING THE 8MM WRENCH REMOVE THE SIX ACORN NUTS (1E), SIX FLAT WASHERS (1F), AND THE LEFT AND RIGHT SADDLEBAG REFLECTORS (1G). SET THE REFLECTORS ASIDE AND KEEP THE ACORN NUTS (1E) AND FLAT WASHERS (1F) FOR REASSEMBLY.

2. USING THE CENTER PUNCH AND HAMMER, MARK EACH SADDLEBAG DOOR (2A) AT LOCATION (2B).

3. USING THE 7/16" DRILL BIT, DRILL THROUGH EACH SADDLEBAG DOOR (2A) AT LOCATION (2B).

4. USING THE CENTER PUNCH AND HAMMER, MARK THE LEFT HAND AND RIGHT HAND SADDLEBAG REAR SURFACE CAVITIES (3A) AT LOCATION (3B).

5. USING THE 7/16" DRILL BIT, DRILL THROUGH THE LEFT HAND AND RIGHT HAND SADDLEBAG REAR SURFACE CAVITIES (3A) AT LOCATION (3B).

6. USING THE 7/16" DRILL BIT, ENLARGE BY DRILLING OUT THE THREE MOUNTING HOLES IN THE SADDLEBAG DOOR TO ALLOW TOLERANCE FOR PROPER FITTING AND CENTERING OF THE SADDLEBAG LIGHT UNIT.

7. PUSH THE WIRING HARNESS (4A) FROM THE LEFT AND RIGHT SADDLEBAG LIGHTS (1H) THROUGH THE 7/16" DRILLED HOLE AT LOCATION (4B) ON THE DOOR PANELS (4C). NOTE THE ANGLED ENDS ON THE LIGHTS (1H) FACE THE FRONT OF THE MOTORCYCLE WITH THE WIRING HARNESS (4A) TO THE REAR.

8. USING THE 8MM WRENCH, ATTACH THE LIGHTS (1H) TO THE LEFT AND RIGHT DOOR PANELS (4C) USING THE ACORN NUTS (4D) AND FLAT WASHERS (4E) REMOVED IN STEP 1C, BEING CAREFUL NOT TO PINCH THE WIRE HARNESS (4A).

9. USING ELECTRICAL TAPE, (4H) TAPE THE WIRE HARNESS TO THE REAR DOOR PANEL HINGE ARM (4F) ON EACH SIDE. BE SURE TO ALLOW SUFFICIENT SLACK FOR THE DOOR PANELS TO OPEN COMPLETELY.

10. ROUTE THE WIRING HARNESS (4A) FROM INSIDE THE SADDLEBAGS THROUGH THE 7/16" DRILLED HOLES ON THE SADDLEBAG REAR CAVITY SURFACES AT LOCATION (4G).

11. SPLICE THE LIGHT WIRE HARNESS (4A) TO THE MOTORCYCLE RUNNING LIGHTS IN THE REAR SURFACE CAVITIES (3A) BEHIND THE SADDLEBAGS. ATTACH THE BROWN LIGHT POWER WIRE (+) TO BROWN AND THE GREEN LIGHT GROUND WIRE (-) TO GREEN ON THE MOTORCYCLE.

12. TURN ON THE IGNITION AND CHECK THAT THE SADDLEBAG LIGHTS (1H) AND THE MOTORCYCLE RUNNING LIGHTS AND STOP LIGHTS WORK PROPERLY.

13. USING A WATER PROOF SEALANT, SEAL THE WIRING AND DRILLED ACCESS HOLES (4B & 4G) TO PREVENT MOISTURE FROM ENTERING.

14. REPLACE THE LOWER CORNER COVERS, SCREWS AND TRIM COVER PIECES BY REVERSING STEPS 1A AND 1B, BEING CAREFUL NOT TO PINCH THE WIRING HARNESS (4A).

FIGURE #1

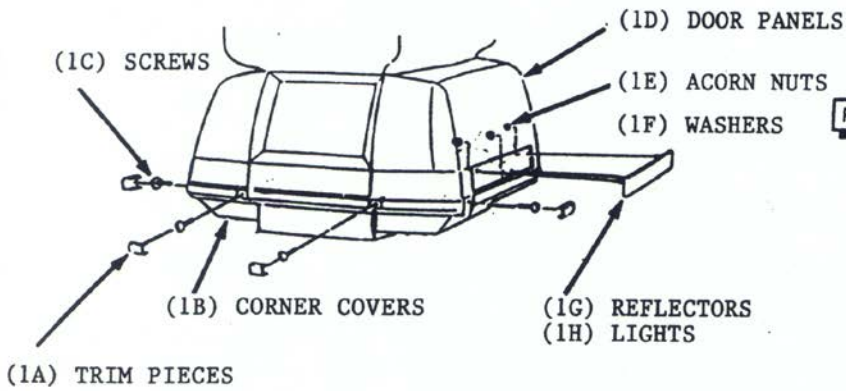

FIGURE #2

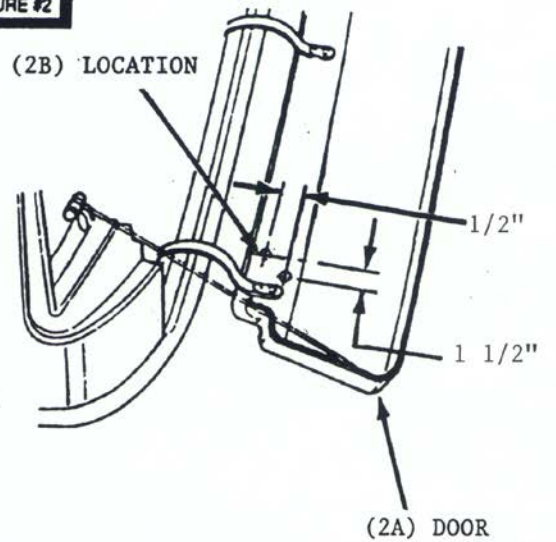

FIGURE #3

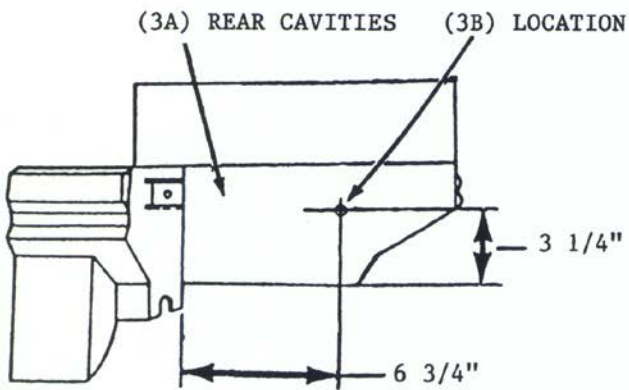

FIGURE #4

