

# BIG BIKE PARTS™

## INSTALLATION INSTRUCTIONS

SADDLEBAG TOP  
RAIL SET  
PART NO. 2-417

FOR HONDA GL1500  
GOLD WING MODEL

Copyright© 2000 by Big Bike Parts, Inc.™ No part of this instruction sheet may be reproduced without the written permission of Big Bike Parts, Inc.™

Revised 7/25/2017

TOOLS REQUIRED: #2 MEDIUM PHILLIPS SCREW DRIVER  
7/32" DRILL BIT & ELECTRICAL DRILL  
3/4" MASKING TAPE  
CENTER PUNCH  
HAMMER  
MARKING PEN

1. COVER THE R/H SADDLEBAG TOP RAIL LEGS WITH MASKING TAPE TO PREVENT SCRATCHING WHEN POSITIONING IN PLACE ON THE SADDLEBAG.
2. POSITION THE SADDLEBAG TOP RAIL SO THE TOP OUTSIDE MOUNTING LEG IS 2 5/8" FROM THE INSIDE EDGE OF THE SADDLEBAG LID (1A). CAREFULLY ADJUST HE RAIL FORWARD OR BACKWARDS SO THAT THE RAIL SITS PROPERLY AND IS NOT INTERFERING WITH THE SADDLEBAG LATCH WHEN MOUNTED.
3. LIFT THE RAIL SLIGHTLY OFF THE SURFACE OF THE SADDLEBAG AND PLACE SHORT STRIPS OF 3/4" MASKING TAPE UNDER THE THREE MOUNTING LEG LOCATIONS. (1B)
4. RE-CHECK THE RAIL POSITION, ADJUST IF NECESSARY. USING A MARKING PEN, OUTLINE EACH MOUNTING LEG ONTO THE MASKING TAPE.
5. SET THE RAIL ASIDE. USING A CENTER PUNCH AND HAMMER, MARK THE THREE HOLE CENTERS. DRILL 7/32" DIAMETER HOLES THROUGH THE SADDLEBAG DOOR.
6. CAREFULLY REMOVE ALL MASKING TAPE FROM THE RAIL AND SADDLEBAG. CLEAN IF NECESSARY. ATTACH RAIL WITH STEEL WASHERS, SCREWS AND RUBBER WASHERS FROM INSIDE THE SADDLEBAG (1C). LOCTITE COULD BE USED TO ASSURE THE SCREWS STAY PERMANENTLY MOUNTED.
7. REPEAT STEPS 1 THROUGH 6 FOR L/H RAIL INSTALLATION.

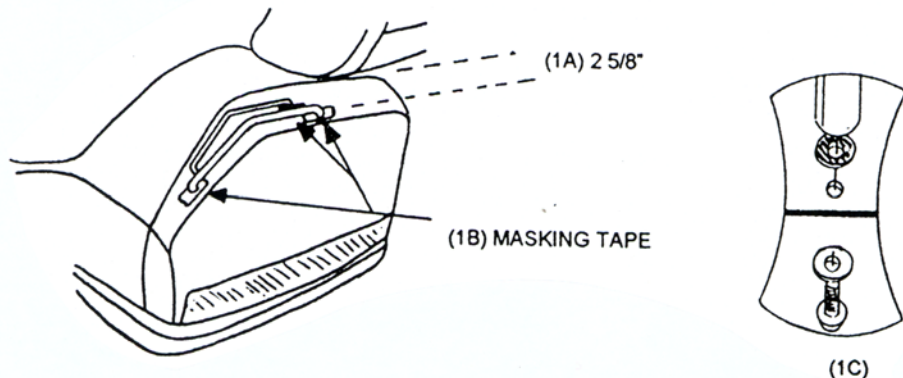

# BIG BIKE PARTS™

## INSTALLATION INSTRUCTIONS

SADDLEBAG TOP  
RAIL SET  
PART NO. 2-417

FOR HONDA GL1500  
GOLD WING MODEL

Copyright© 2000 by Big Bike Parts, Inc.™ No part of this instruction sheet may be reproduced without the written permission of Big Bike Parts, Inc.™

Revised 7/25/2017

TOOLS REQUIRED: #2 MEDIUM PHILLIPS SCREW DRIVER  
7/32" DRILL BIT & ELECTRICAL DRILL  
3/4" MASKING TAPE  
CENTER PUNCH  
HAMMER  
MARKING PEN

1. COVER THE R/H SADDLEBAG TOP RAIL LEGS WITH MASKING TAPE TO PREVENT SCRATCHING WHEN POSITIONING IN PLACE ON THE SADDLEBAG.
2. POSITION THE SADDLEBAG TOP RAIL SO THE TOP OUTSIDE MOUNTING LEG IS 2 5/8" FROM THE INSIDE EDGE OF THE SADDLEBAG LID (1A). CAREFULLY ADJUST HE RAIL FORWARD OR BACKWARDS SO THAT THE RAIL SITS PROPERLY AND IS NOT INTERFERING WITH THE SADDLEBAG LATCH WHEN MOUNTED.
3. LIFT THE RAIL SLIGHTLY OFF THE SURFACE OF THE SADDLEBAG AND PLACE SHORT STRIPS OF 3/4" MASKING TAPE UNDER THE THREE MOUNTING LEG LOCATIONS. (1B)
4. RE-CHECK THE RAIL POSITION, ADJUST IF NECESSARY. USING A MARKING PEN, OUTLINE EACH MOUNTING LEG ONTO THE MASKING TAPE.
5. SET THE RAIL ASIDE. USING A CENTER PUNCH AND HAMMER, MARK THE THREE HOLE CENTERS. DRILL 7/32" DIAMETER HOLES THROUGH THE SADDLEBAG DOOR.
6. CAREFULLY REMOVE ALL MASKING TAPE FROM THE RAIL AND SADDLEBAG. CLEAN IF NECESSARY. ATTACH RAIL WITH STEEL WASHERS, SCREWS AND RUBBER WASHERS FROM INSIDE THE SADDLEBAG (1C). LOCTITE COULD BE USED TO ASSURE THE SCREWS STAY PERMANENTLY MOUNTED.
7. REPEAT STEPS 1 THROUGH 6 FOR L/H RAIL INSTALLATION.

