

Copyright © 2019 by Big Bike Parts, Inc. No part of this instruction sheet may be reproduced without the written permission of Big Bike Parts, Inc.

PART NO. 21-334/21-334BK

1-1/4" HIGHWAY RAIL PEG SET

FITMENT: ALL 1-1/4" ROUND HIGHWAY BARS

9/4/2019

TOOLS NEEDED: RUBBING ALCOHOL

LINT FREE TOWEL

4MM ALLEN WRENCH**

REMOVABLE THREAD LOCK

PLEASE READ THROUGH AND UNDERSTAND THESE INSTRUCTIONS BEFORE BEGINNING.

USE REMOVABLE THREAD LOCK ON ALL SCREWS.

**ONLY USE AN "L" STYLE OR SOCKET TYPE ALLEN WRENCH AND TIGHTEN IN SEQUENCE SHOWN BELOW.

ESTIMATED INSTALLATION TIME: 15 TO 30 MIN.

INSTALLATION:

1. USING RUBBING ALCOHOL AND A LINT FREE TOWEL CLEAN THE AREA ON THE HIGHWAYS BARS WHERE THE PEGS ARE GOING TO BE INSTALLED.
2. USING **FIG. 1** FOR REFERENCE DETERMINE WHICH PEG IS FOR THE RIGHT SIDE HIGHWAY BAR.
3. REMOVE THE FOUR M5 X 16MM SCREWS AND THE CLAMP FROM THE RIGHT PEG. SEE **FIG. 2**.
4. PLACE THE RIGHT PEG ON THE HIGHWAY BAR IN THE LOCATION YOU WANT IT MOUNTED.
5. PLACE THE CLAMP OVER THE TUBE AND INSTALL THE FOUR SCREWS. TIGHTEN THE SCREW ENOUGH THAT YOU CAN STILL ROTATE THE PEG.
6. REPEAT STEPS 3 THROUGH 5 FOR THE LEFT SIDE PEG.
7. ADJUST BOTH PEGS BY HAND SO THAT THE RIGHT SIDE AND THE LEFT SIDE HEIGHT AND ANGLE MATCH EACH OTHER.
8. USING THE SEQUENCE SHOWN IN **FIG. 3** SLOWLY AND EVENLY TIGHTEN BOTH PEGS.
9. RECHECK THE M5 X 16MM SCREWS AFTER RIDING THE BIKE.

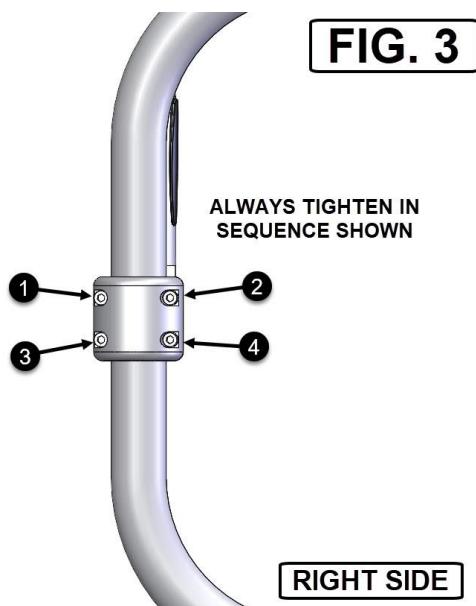
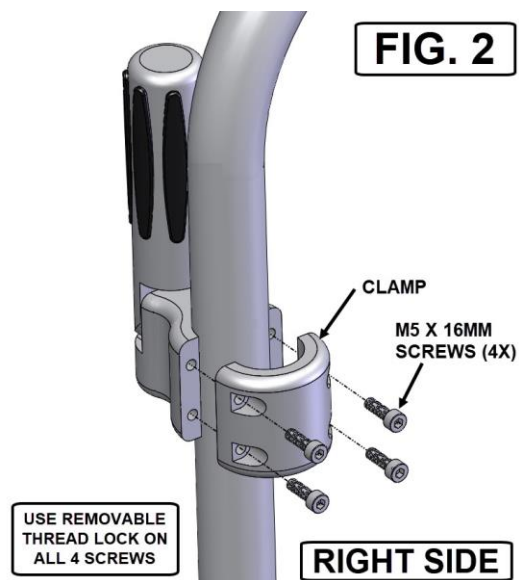
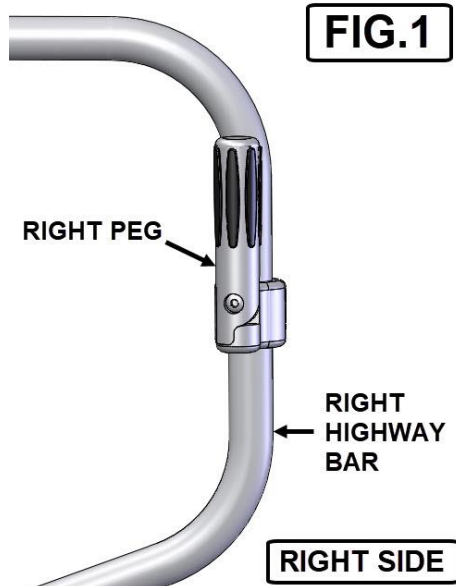

NOTICE

IGNORING THE CONTENTS OF THESE INSTRUCTIONS MAY AFFECT THE PRODUCT PERFORMANCE AND FUNCTIONALITY. NOT FOLLOWING THESE INSTRUCTION MAY CAUSE DAMAGE TO THE PRODUCT OR THE VEHICLE TO WHICH IT IS BEING ATTACHED.