

Copyright © 2015 by Big Bike Parts, Inc. No part of this instruction sheet may be reproduced without the written permission of Big Bike Parts, Inc.

Part No. 21-911 & 21-912

VANTAGE & BEACHCOMBER BOARDS

10/25/2019

HARLEY-DAVIDSON 1986-NEWER

TOOLS NEEDED: SNAP RING PLIER

7/32" ALLEN WRENCH

9/16" WRENCH

8MM ALLEN WRENCH

PLEASE READ THROUGH AND UNDERSTAND THESE INSTRUCTIONS BEFORE BEGINNING.

ESTIMATED INSTALLATION TIME: 30 TO 45 MIN.

INSTALLATION:

1. STARTING ON THE RIGHT SIDE USING A SNAP RING PLIER REMOVE THE SNAP RING AND PIN FROM THE RIGHT PEG. NOTE: SOME BIKES MAY HAVE A BOLT AND NUT INSTEAD OF A PIN. THESE ITEMS WILL NOT BE REUSED.
2. SLIDE THE PEG AND SPRING WASHER OUT OF THE MOUNT. THE SPRING WASHER WILL BE REUSED.
3. TAKE ONE OF THE 7/16" MOUNTS FROM THE KIT AND WITH ROUNDED EDGE TO THE TOP PLACE THE SPRING WASHER ON THE SIDE AS SHOWN IN FIG. 1.
4. SLIDE THE MOUNT AND SPRING WASHER INTO THE MOUNT AND ALIGN THE HOLES.
5. INSTALL THE 3/8-24 X 1-1/4" BUTTON HEAD BOLT FROM THE FRONT SIDE AS SHOWN IN FIG. 1. USING A 7/32" ALLEN WRENCH TIGHT THE BOLT. NOTE: THIS WILL LOCK THE MOUNT SO THAT IT DOES NOT SWIVEL.
6. USING A 7/32" ALLEN WRENCH TO KEEP THE BOLT FROM MOVING INSTALL THE LOCK NUT ON THE BOLT AND TIGHTEN WITH A 9/16" WRENCH.
7. INSTALL THE M10 X 28MM LONG BOLT THROUGH NEW BOARD AND INTO THE NEW MOUNT ON THE BIKE AS SHOWN IN FIG.1.
8. ROTATE THE BOARD TO THE DESIRED POSITION AND USING AN 8MM ALLEN WRENCH TIGHTEN THE BOLT.
9. REPEAT THE STEPS ABOVE ON THE LEFT SIDE.

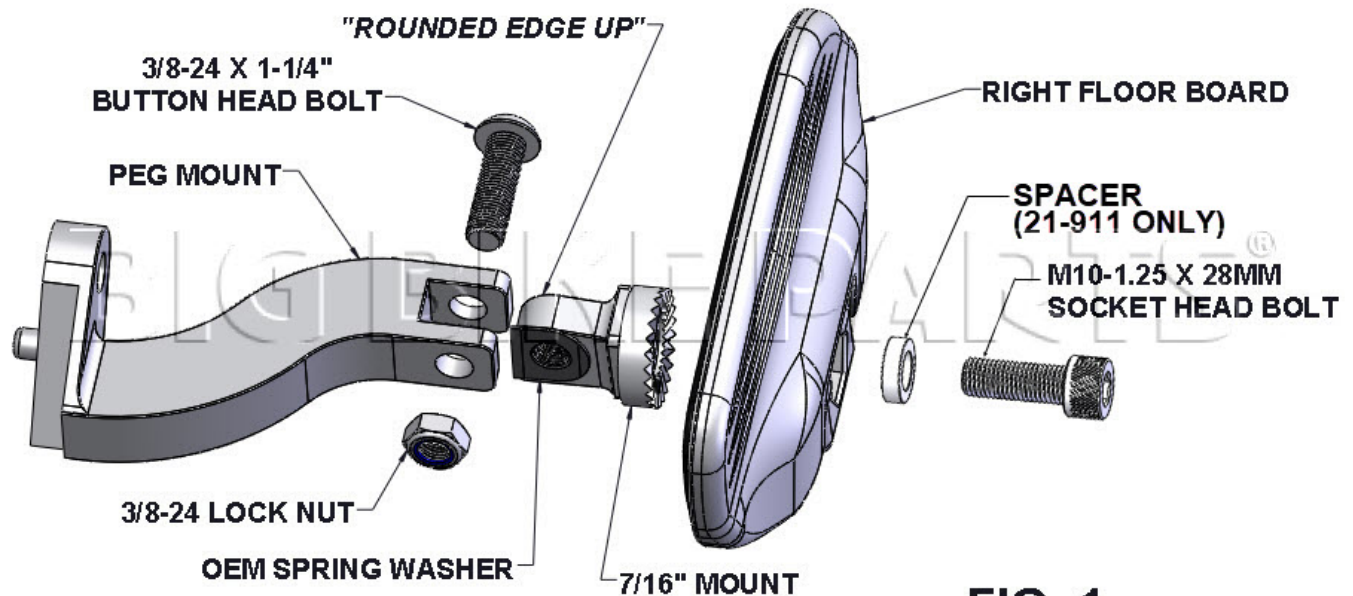
**FIG. 1****NOTICE**

IGNORING THE CONTENTS OF THESE INSTRUCTIONS MAY AFFECT THE PRODUCT PERFORMANCE AND FUNCTIONALITY. NOT FOLLOWING THESE INSTRUCTION MAY CAUSE DAMAGE TO THE PRODUCT OR THE VEHICLE TO WHICH IT IS BEING ATTACHED.

NOTICE

THIS SET CONTAINS EXTRA HARDWARE ITEMS THAT WILL NOT BE USED FOR THIS INSTALLATION