

Copyright © 2023 by Big Bike Parts, Inc. No part of this instruction sheet may be reproduced without the written permission of Big Bike Parts, Inc.

PART NO. 30-108

SMART MOUNT™ BACKREST

Revised 5/5/2023

FITMENT:

VICTORY CROSS COUNTRY/CROSS ROADS/ HARDBALL/ CCT/ MAGNUM
2010-NEWER

TOOLS NEEDED:	6MM ALLEN WRENCH	4MM ALLEN WRENCH	3/16" ALLEN WRENCH	
	13MM WRENCH	17MM WRENCH	7/16" WRENCH	REMOVABLE THREAD LOCK

PLEASE READ THROUGH AND UNDERSTAND THESE INSTRUCTIONS BEFORE BEGINNING. *USE A REMOVABLE THREAD LOCK ON ALL FASTENERS.*
ESTIMATED INSTALLATION TIME: 20 TO 30 MIN.

INSTALLATION:

1. THREAD THE TWO M10 X 25MM SCREWS THROUGH THE RISER AND INTO THE MOUNT FROM THE SIDE SHOWN IN FIG. 1.
2. POSITION THE SCREWS SO THAT THEY ARE CLOSE TO THE RISER BUT YOU ARE STILL ABLE TO MOVE THE RISER.
3. INSTALL THE TWO M10 LOCK NUTS ON THE BACK SIDE AS SHOWN IN FIG. 1 AND TIGHTEN.
4. REMOVE THE RISER BY SLIDING IT UP SO THAT THE LARGE OPENING LINES UP WITH THE TOP SCREW. PULL IT FORWARD TO REMOVE. SEE FIG. 2.
5. REMOVE BOTH SIDE COVERS ON THE BIKE BY PULLING THEM STRAIGHT OUT.
6. USING A 6MM ALLEN WRENCH REMOVE THE TWO SCREWS HOLDING THE FRONT OF THE SEAT TO THE BIKE. SEE FIG. 3.
7. LIFT THE SEAT FROM THE FRONT AND REMOVE IT. FEED THE PASSENGER STRAP THROUGH THE HOLE AS YOU REMOVE THE SEAT.
8. REMOVE THE TWO BOLTS AND THE PASSENGER STRAP MOUNT FROM THE BIKE. THESE ITEMS WILL NOT BE REUSED.
9. PLACE THE MOUNT AS SHOWN IN FIG. 4 AND INSTALL THE TWO M8 X 20MM BOLTS WITH LOCK WASHER AND TIGHTEN.
10. REINSTALL THE SEAT AND SIDE COVERS.
11. ASSEMBLE THE BACKREST ASSEMBLY TO THE RISER ASSEMBLY USING THE HARDWARE SHOWN IN FIG. 5.
13. SNAP THE POUCH ON THE BACK OF THE BACKREST PAD.
14. INSTALL THE RISER ON THE MOUNT BY SLIDING IT INTO THE FRONT PART ON THE HOLE IN THE SEAT AND ALIGNING THE TOP SCREW WITH THE LARGE HOLE IN THE RISER. PUSH THE RISER BACK TIGHT TO THE MOUNT AND PUSH DOWN.
15. USING THE ADJUSTMENT PLATE AND THE MOUNTING HOLES IN THE TOP BRACKET (ON THE RISER ASSEMBLY), ADJUST THE PAD TO THE DESIRED POSITION.

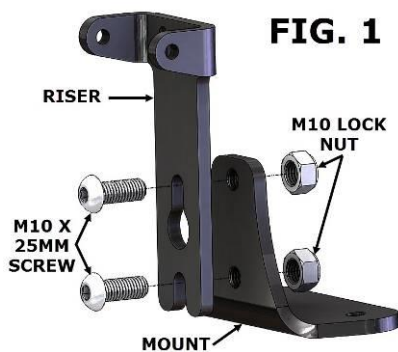

FIG. 1

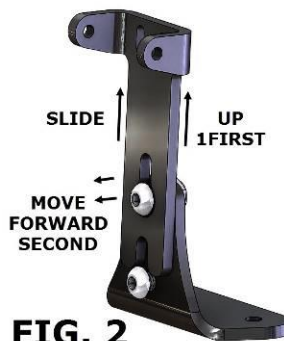

FIG. 2

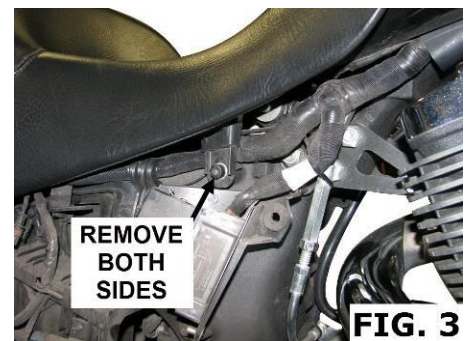

FIG. 3



FIG. 4



FIG. 5

WARNING

BACKREST IS DESIGNED TO SUPPORT RIDERS LOWER BACK WHEN RIDING. DO NOT APPLY EXCESSIVE FORCE BY PUSHING BACK WITH YOUR FULL BODY WEIGHT. DO NOT USE BACKREST TO LIFT OR SUPPORT MOTORCYCLE.

NOTICE

IGNORING THE CONTENTS OF THESE INSTRUCTIONS MAY AFFECT THE PRODUCT PERFORMANCE AND FUNCTIONALITY. NOT FOLLOWING THESE INSTRUCTION MAY CAUSE DAMAGE TO THE PRODUCT OR THE VEHICLE TO WHICH IT IS BEING ATTACHED.