

Revised 9/17/08

TOOLS REQUIRED:

4MM ALLEN WRENCH	10MM WRENCH
5MM ALLEN WRENCH	9/16 WRENCH & SOCKET
6MM ALLEN WRENCH	12MM WRENCH

COMPONENT LIST:

A (4) 3/8" X 1.25" LONG BOLT	F (2) M6 X 18MM SOCKET HEAD CAP SCREW	L (1) RECEIVER
B (8) 3/8" FLAT WASHER	G (1) HITCH FRAME ASSEMBLY	M (1) 3/8" X 3/4" LONG BOLT
C (4) 3/8" NYLOC NUT	H (1) HITCH PIN	N (1) 3/8" NUT
D (2) 1" THREE PIECE CLAMP	J (1) HAIR PIN	O (2) 1/4" WASHERS
E (1) "T" BRACKET	K (1) 1 7/8" BALL	

INSTALLATION:

1. PLACE YOUR BIKE ON ITS CENTER STAND.
2. USING A 5MM ALLEN WRENCH REMOVE THE FOUR SCREWS (1A) HOLDING THE REAR SHROUD (1B) TO THE SADDLEBAGS.
NOTE: SOME MODELS WILL HAVE A FIFTH SCREW BEHIND THE LICENSE PLATE WHICH WILL ALSO NEED TO BE REMOVED.
3. USING A 10MM WRENCH REMOVE THE TWO BOLTS (1C) HOLDING THE SADDLEBAG FRAME CROSS BRACE (1D) TO THE SADDLEBAG FRAME.
4. USING A 6MM ALLEN WRENCH LOOSEN (DO NOT REMOVE) THE TWO LEFT SIDE MUFFLER CLAMP BOLTS (2A). USING THE 12MM WRENCH REMOVE THE MUFFLER BRACKET BOLT (2C). THIS WILL ALLOW YOU TO SWING THE MUFFLER (2B) DOWN OUT OF THE WAY.
5. REPEAT STEP #4 FOR THE RIGHT SIDE.
6. ATTACH THE LEFT SIDE 1" THREE PIECE CLAMPS 'D' TO THE SADDLEBAG GUARDS (2D). LEAVE LOOSE TO ALLOW FOR MOVEMENT.
7. REPEAT STEP #6 FOR THE RIGHT SIDE.
8. SLIDE THE HITCH FRAME ASSEMBLY 'G' IN PLACE (3A).
9. REATTACH THE LEFT AND RIGHT SIDE MUFFLER BY REVERSING STEPS 4 & 5.
10. INSTALL THE "T" BRACKET 'E' OVER THE BAG FRAME CROSS BRACE, USING M6 X 18MM SOCKET HEAD CAP SCREWS 'F' AND TIGHTEN USING 10MM WRENCH.
11. LOOSELY SECURE THE LEFT SIDE HITCH MOUNTING TAB TO THE 1" THREE PIECE CLAMP 'D'. USING 3/8" X 1 1/4" LONG BOLTS 'A', 3/8" FLAT WASHERS 'B', 3/8" NYLOC HEX NUTS 'C'. LEAVE BOLTS LOOSE UNTIL LATER. (DO THE SAME ON RIGHT SIDE)
12. INSTALL THE "T" BRACKET 'E' TO THE HITCH FRAME ASSEMBLY 'G', USING THE 3/8" X 1 1/4" LONG BOLTS 'A', 3/8" FLAT WASHERS 'B', AND NYLOC NUTS 'C'.
13. MAKE SURE HITCH FRAME ASSEMBLY IS SQUARE WITH BACK OF BIKE TO ENSURE THAT YOUR TRAILER WILL TRACK PROPERLY DOWN THE ROAD. THEN TIGHTEN DOWN ALL THE NUTS AND BOLTS.
14. REPLACE THE REAR SHROUD (1B) BY REVERSING STEP #2.
15. FASTEN THE 1 7/8" HITCH BALL 'K' TO RECEIVER 'L' AND SECURELY TIGHTEN.
16. SLIDE THE RECEIVER 'L' INTO THE RECEIVER TUBE, PLACING THE HITCH PIN 'H' THROUGH BOTH AND SECURE WITH HAIR PIN 'J'.
17. SNUG ANTI CHATTER BOLT 'M'
(DO NOT OVER-TIGHTEN) AND TIGHTEN JAM NUT 'N'.

CAUTION: FOR USE IN CONJUNCTION WITH PROFESSIONALLY MANUFACTURED MOTORCYCLE TRAILERS. DO NOT EXCEED THE TOTAL RECOMMENDED TRAILER LOADS OF YOUR MOTORCYCLE OR MOTORCYCLE TRAILER MANUFACTURER.

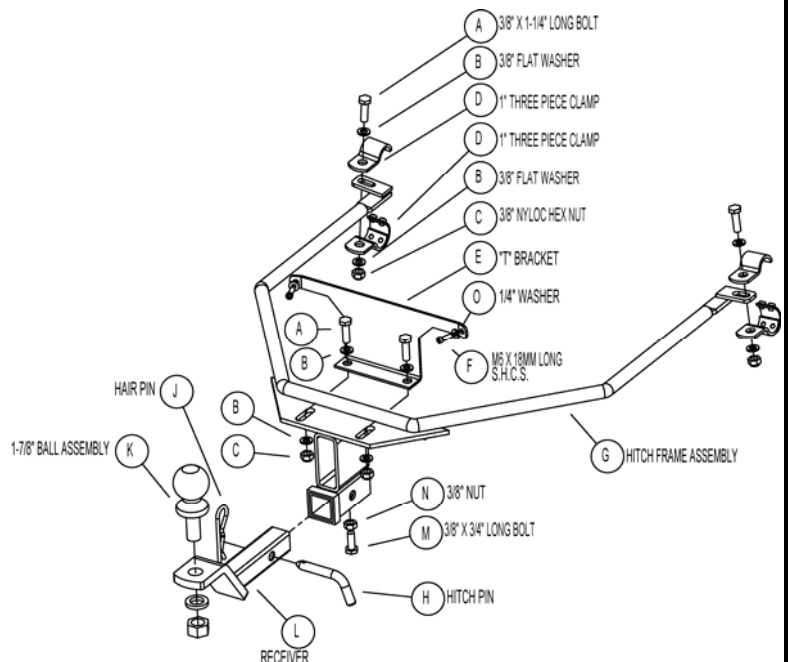

NOTE: YOUR RECEIVER HITCH COMES WITH TWO MOUNTING HOLES ALLOWING YOU TO INSTALL A MUD FLAP BEHIND THE RECEIVER TUBE PLATE.

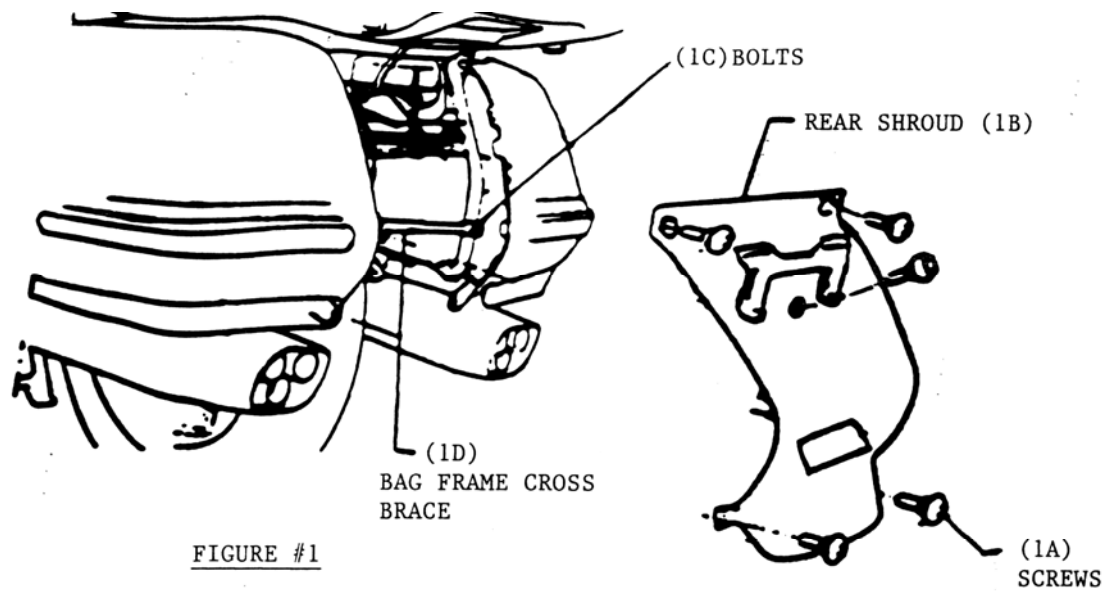

FIGURE #1

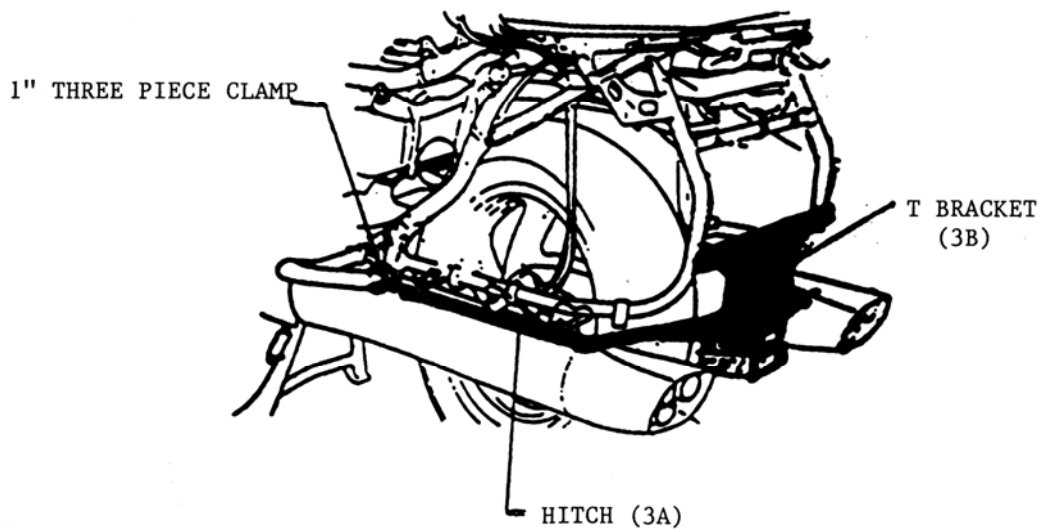
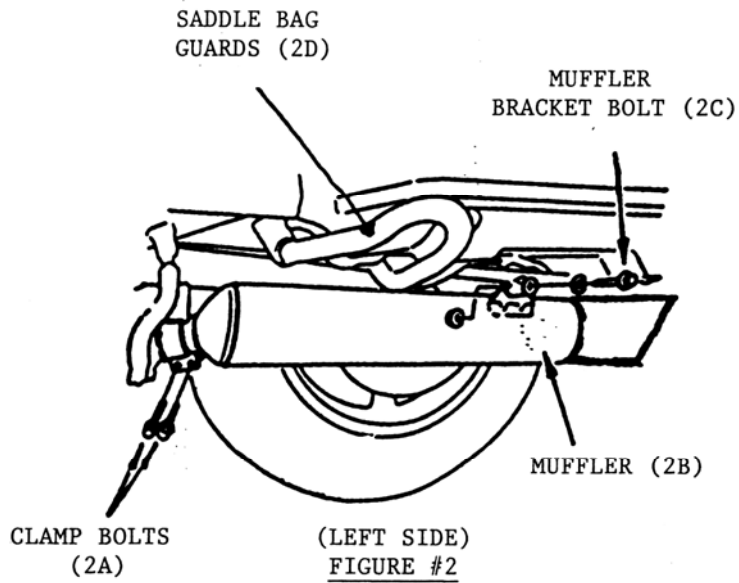

FIGURE # 3