

BIG BIKE PARTS® INSTALLATION INSTRUCTIONS

Copyright® 2006 by Big Bike Parts, Inc. No part of this instruction sheet may be reproduced without the written permission of Big Bike Parts, Inc.

PART NO. 52-766 TRUNK T.S. CONVERSION HARNESS FITS HONDA GL1800 GOLD WING

Revised 02/28/07

TOOLS NEEDED: 5MM ALLEN WRENCH
6MM ALLEN WRENCH

8MM SOCKET WRENCH

PHILLIPS SCREWDRIVER
FLAT SCREWDRIVER

1. REMOVE THE SEAT BY REMOVING THE FOUR BOLTS LOCATED IN THE PASSENGER HANDLES USING A 6MM ALLEN WRENCH. (SEE FIGURE #1)
2. REMOVE THE REAR FENDER PANEL BY REMOVING THE FOUR BOLTS IN EACH CORNER USING A 5MM ALLEN WRENCH.
3. REMOVE THE LEFT AND RIGHT FAIRING MOLDING BY CAREFULLY PULLING OUTWARD SO THE FRONT POCKETS CAN BE REMOVED. (SEE FIGURE #2)
4. REMOVE BOTH FRONT POCKETS. USE A PHILLIPS SCREWDRIVER ON THE RIGHT SIDE. PUSH THE CENTER OF THE LOCKPINS INWARD ON THE LEFT AND PULL UPWARD TO RELEASE. REMOVE THE LOCKING CABLE FROM THE POCKET ON THE RIGHT SIDE. (ON AIRBAG MODELS, REMOVE THE UPPER RIGHT CONTROL PANEL WITH 5MM ALLEN WRENCH.
5. LOCATE THE LOWER FOUR FAIRING BOLTS ON THE LEFT AND RIGHT SIDES THAT WERE UNDERNEATH THE FAIRING MOLDING YOU REMOVED IN STEP #3. REMOVE THE BOLTS USING A 5MM ALLEN WRENCH.
6. REMOVE THE LEFT SIDE COVER TO EXPOSE THE BATTERY BY GENTLY PULLING ON THE PANEL. REPEAT FOR THE PANEL ON THE RIGHT SIDE.
7. REMOVE THE REAR TRUNK LIGHTS BY REMOVING THE THREE ACORN NUTS IN EACH CORNER WITH THE 8MM SOCKET WRENCH. TURN EACH LIGHT BULB SOCKET TO REMOVE FROM FIXTURE AND SET THE LIGHTS TO THE SIDE.
8. REMOVE THE TRUNK TRIM PIECES AND TRUNK BOTTOM PANEL BY REMOVING FOUR PHILLIPS HEAD SCREWS ON EACH OF THE INSIDE TRUNK WALLS. THEN REMOVE THE THREE PHILLIPS HEAD SCREWS ON THE OUTSIDE SURFACE OF THE BACK OF THE TRUNK. GENTLY REMOVE THE TRUNK BOTTOM PANEL. (SEE FIGURES #3 AND #4)
9. ROUTE THE GREEN WIRES WITH THE RED STRIPE LABELED "L" AND THEIR CONNECTORS UP THROUGH THE HOLE TO THE LEFT TRUNK LIGHT CAVITY. REPEAT WITH WIRES LABELED "R" FOR THE RIGHT SIDE. THE WHITE MALE CONNECTORS ON THE HARNESS WILL BE CONNECTED TO THE TRUNK LIGHT BULBS AND THE BLACK FEMALE CONNECTORS ARE CONNECTED TO THE BLACK MALE CONNECTORS ON THE BIKE.
10. ON THE WIRE HARNESS WITH THE IN LINE FUSE, FEED THE WHITE TWO PIN PLUGS AND THE BLACK SIX PIN PLUG FROM UNDER THE SEAT TO BEHIND THE REAR FENDER PANEL.
- 11A. UNDER THE REAR FENDER PANEL, REMOVE ALL THE CONNECTORS FROM THE BLACK RUBBER BOOT. CONNECT THE WHITE THREE PIN FEMALE CONNECTOR WITH THE LIGHT BLUE WIRE TO THE BLUE THREE PIN MALE CONNECTOR WITH THE LIGHT BLUE WIRE. THEN CONNECT THE WHITE THREE PIN MALE CONNECTOR WITH THE LIGHT BLUE WIRE TO THE BLUE THREE PIN FEMALE CONNECTOR WITH THE LIGHT BLUE WIRE.
- 11B. CONNECT THE WHITE THREE PIN FEMALE CONNECTOR WITH THE ORANGE WIRE TO THE RED THREE PIN MALE CONNECTOR. THEN CONNECT THE WHITE THREE PIN MALE CONNECTOR WITH THE ORANGE WIRE TO THE RED THREE PIN FEMALE CONNECTOR.
- 11C. CONNECT THE SIX PIN FEMALE CONNECTORS ON THE RELAY ASSEMBLY TO THE SIX PIN MALE CONNECTORS WITH THE CORRESPONDING COLORS.
- 11D. CONNECT THE WHITE FEMALE TWO PIN CONNECTOR WITH GREEN WIRES TO THE BLUE MALE TWO PIN CONNECTOR WITH GREEN WIRES. THEN CONNECT THE WHITE TWO PIN MALE CONNECTOR WITH GREEN WIRES TO THE BLUE TWO PIN FEMALE CONNECTOR WITH GREEN WIRES.
12. ROUTE THE RED WIRE WITH THE FUSE UNDERNEATH THE FRAME TO THE BATTERY. THEN REMOVE THE POSITIVE BATTERY SCREW WITH A FLAT HEAD SCREWDRIVER AND PLACE THE RED WIRES RING TERMINAL ONTO THE SCREW AND REINSTALL.
13. REMOVE THE NUTS ON THE BOTTOM CORNERS OF THE GAS TANK PANEL WITH A 10MM SOCKET WRENCH.
14. ROUTE THE LIGHT BLUE WIRE WITH THE SPADE CONNECTOR ALONG THE RIGHT SIDE OF THE FRAME AND UNDER THE BAR ACROSS THE TOP OF THE GAS TANK. THEN ROUTE BEHIND THE GAS TANK PANEL ABOUT THE NUT REMOVED IN PREVIOUS STEP AND UP TO THE RIGHT POCKET CAVITY. REPEAT WITH ORANGE WIRE ON THE LEFT SIDE OF THE BIKE.
15. PUSH THE RIGHT SIDE MIRROR FORWARD AND PULL BACK THE RUBBER SEAL TO EXPOSE THE WIRING. ATTACH ONE OF THE T-TAPS SUPPLIED TO THE LIGHT BLUE WIRE WITH WHITE STRIPE. REPEAT ON LEFT SIDE BY PLACING A T-TAP ON THE ORANGE WIRE WITH WHITE STRIPE. PLUG THE SPADE CONNECTORS INTO THE T-TAPS ON EACH SIDE.
16. ATTACH RELAY ASSEMBLY WITH ZIP TIE TO THE OTHER GROUP OF WIRES IN THE BACK OF THE BIKE.
17. CHECK THE SYSTEM FOR FUNCTION AND RE-ASSEMBLE THE BIKE.

FAIRING MOLDING

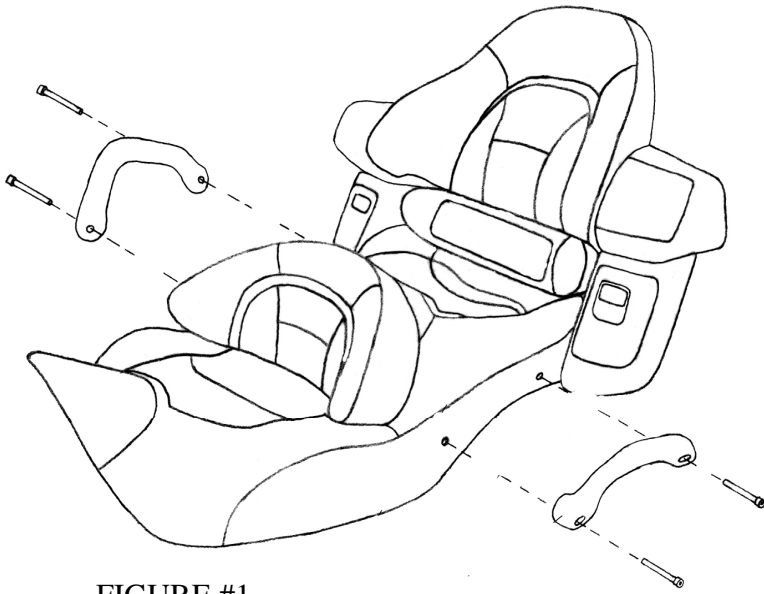

FIGURE #1

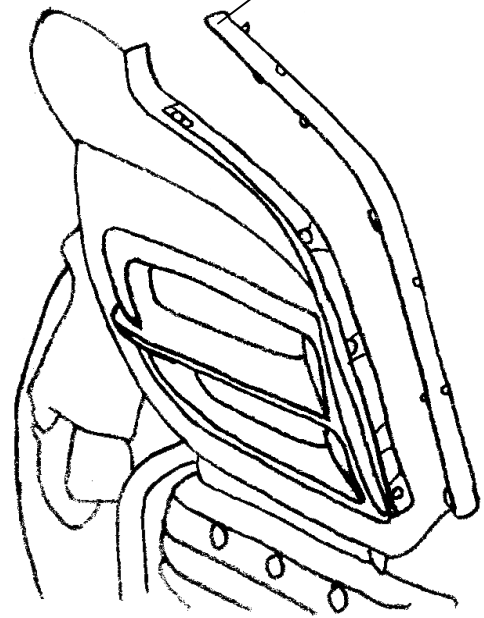

FIGURE #2

TRUNK TRIM PIECE

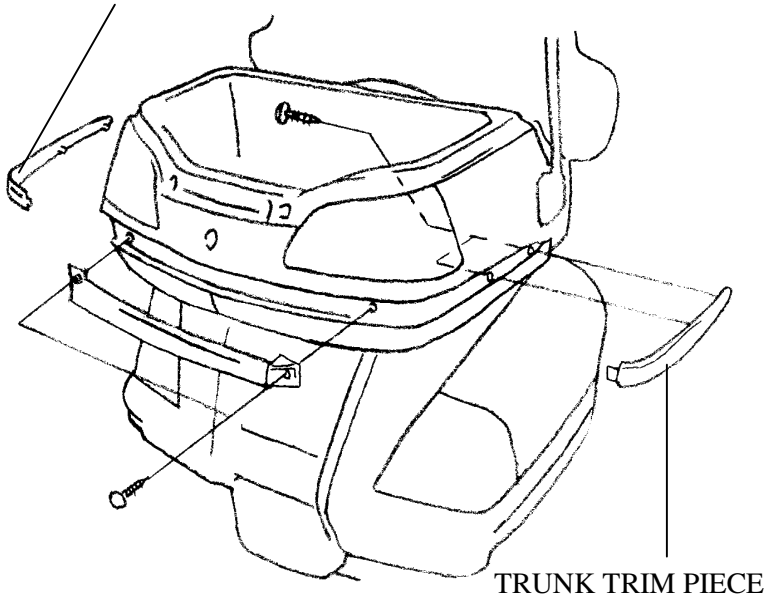

FIGURE #3

TRUNK TRIM PIECE

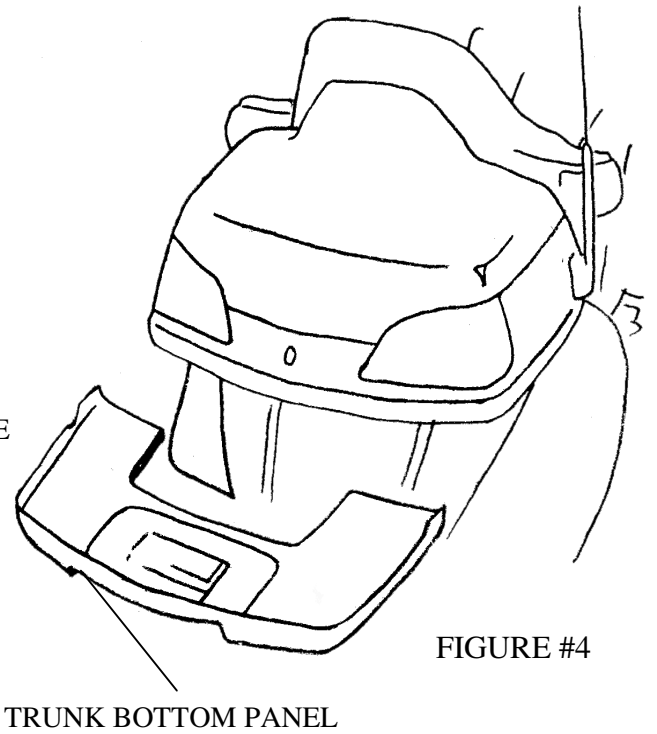

FIGURE #4

TRUNK BOTTOM PANEL