

Copyright © 2013 by Big Bike Parts, Inc. No part of this instruction sheet may be reproduced without the written permission of Big Bike Parts, Inc.

PART NO. 52-824**VERTICAL INTAKE TRIM WITH LEDS****HONDA GOLDWING GL1800
2012-2013**

3/6/2013

TOOLS NEEDED:	5MM ALLEN WRENCH RUBBING ALCOHOL	WIRE CRIMPER DRILL	PLIER MARKER OR PENCIL	FLAT SCREWDRIVER	5/16" (8MM) DRILL BIT
----------------------	-------------------------------------	-----------------------	---------------------------	------------------	-----------------------

PLEASE READ THROUGH AND UNDERSTAND THESE INSTRUCTIONS BEFORE BEGINNING.

INSTALLATION

1. REMOVE THE GROUND CABLE FROM THE BATTERY.
2. USING A MARKER OR A PENCIL MARK THE LOCATION SHOWN IN FIGURE 1 ON BOTH THE RIGHT AND LEFT VERTICAL INTAKES ON THE FRONT OF THE FAIRING.
3. USING A 5/16" DRILL BIT DRILL A HOLE THROUGH THE BLACK PLASTIC IN THE LOCATION YOU MARKED IN STEP 2. BE CAREFUL TO ONLY DRILL THROUGH THE FIRST LAYER.
4. GO TO THE DRIVERS SIDE OF THE FAIRING AND REMOVE THE BLACK COWL TRIM FROM BOTH SIDES. THIS IS THE LONG THIN TRIM THAT STARTS BY THE MIRRORS AND GOES DOWN EACH SIDE. BE CAREFUL NOT TO BREAK THE TAPS WHEN REMOVING.
5. ON THE LEFT SIDE USE A SCREWDRIVER AND PUSH THE CENTER OF THE FOUR PLASTIC RIVETS HOLDING IN THE LEFT SIDE STORAGE POCKET. THEN REMOVE THE POCKET BY PULLING IT OUT.
6. ON THE RIGHT SIDE USE A 5MM ALLEN WRENCH TO REMOVE THE TWO SCREWS HOLDING THE RIGHT HEADLIGHT/PRELOAD PANEL IN PLACE. LIFT THE PANEL AND TWIST IT TO SET ASIDE.
7. FEED THE WIRES FROM THE RIGHT SIDE THROUGH THE HOLE YOU DRILLED IN THE INTAKE PLASTIC. LOOKING THROUGH THE REMOVED PANEL FIND THE WIRES AND PULL THEM UP INTO THE OPENING. REPEAT FOR THE LEFT SIDE INTAKE.
8. GO TO THE LEFT SIDE MIRROR AND ROTATE IT FORWARD AND RELEASE THE RUBBER BOOT TRIM.
9. ATTACH 3 OF THE T-TAPS SUPPLIED TO THE WIRES GOING TO THE MIRROR LIGHT AS FOLLOWS. 1 ON THE GREEN WIRE, 1 ON THE ORANGE WIRE, AND 1 ON THE ORANGE WIRE WITH A WHITE STRIPE.
10. FEED THE WIRES FROM THE LEFT INTAKE TRIM UNDER THE DASH PANEL AND INTO THE MIRROR BASE WHERE YOU JUST INSTALLED THE T-TAPS.
11. CRIMP MALE CONNECTORS ON THE ENDS OF EACH WIRE AND CONNECT AS FOLLOWS. THE BLACK WIRE TO THE GREEN WIRE, THE RED WIRE TO THE ORANGE WIRE, AND THE BLUE WIRE TO THE ORANGE WIRE WITH A WHITE STRIPE.
12. REPEAT STEPS 8-11 ON THE RIGHT SIDE AND CONNECT THE WIRES AS FOLLOWS. BLACK WIRE TO THE GREEN WIRE, THE RED WIRE TO THE LIGHT BLUE WIRE, AND THE BLUE WIRE TO THE DARK BLUE WIRE.
13. CONNECT THE GROUND CABLE ON THE BATTERY AND TEST THE FUNCTION OF THE LIGHTS. YOU SHOULD HAVE RUNNING LIGHTS AND RIGHT AND LEFT TURN LIGHTS.
14. USING RUBBING ALCOHOL AND A CLEAN TOWEL CLEAN THE AREA AROUND THE AIR INTAKES ON BOTH SIDES AND LET DRY.
15. REMOVE THE PVC BACKING FROM THE FOAM TAPE AND INSTALL THE INTAKE TRIMS IN PLACE ON BOTH SIDES.
16. REASSEMBLE THE POCKET AND THE TRIM PANELS MAKING SURE THE NEW WIRING IS SECURE AND WILL NOT INTERFERE WITH ANYTHING.
17. ALLOW THE TAPE TO CURE FOR 24 HOURS BEFORE USING THE MOTORCYCLE.

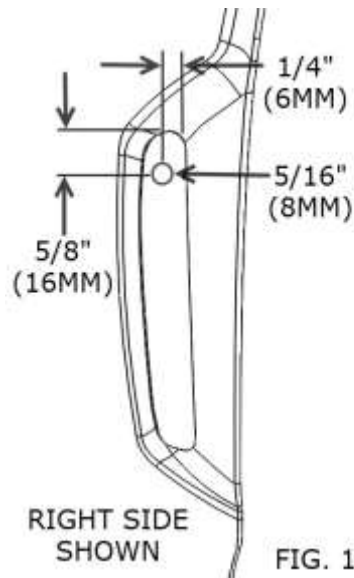

Scan code with
your smartphone
to view video

