

BIG BIKE PARTS®

Copyright © 2013 by Big Bike Parts, Inc. No part of this instruction sheet may be reproduced without the written permission of Big Bike Parts, Inc.

INSTALLATION INSTRUCTIONS

PART NO. 52-832

SMART MOUNT™ BACKREST

FITMENT:

HONDA GL1800 F6B 2013-2017

3/19/2019

TOOLS NEEDED:	Drill	9/32" Drill Bit	6mm Allen Wrench	1/8" Allen Wrench	Lint-free Cloth
	9" min. Serrated Knife	Utility Knife	5mm Allen Wrench	3/16" Allen Wrench	Rubbing Alcohol
	Measuring Tape	7/16" Wrench	4mm Allen Wrench	8mm Wrench	Removable Thread Lock
HARDWARE INCLUDED:	Backrest Pad	Adjustment Plate	10-32 x 1/2" Button Head Cap Screw (2)	1/4-20 x 2-3/4" Socket Head Cap Screw	
	Backrest Mounting Bracket	Top Mounting Bracket	1/4-20 x 3" Socket Head Cap Screw	1/4-20 Nylock Nut (2)	
	Adjusting Bracket	Bottom Mounting Bracket	M6 x 14mm Button Head Cap Screw (2)	M6 Lock Washers (6)	
	Adjustable Tongue	Rubber Strip	M6 x 18mm Button Head Cap Screw (2)	M6 Flat Washers (2)	
	Protective Cover (Rubber Gasket)		M6 x 25mm Socket Head Cap Screw (2)		

PLEASE READ THROUGH AND UNDERSTAND THESE INSTRUCTIONS BEFORE BEGINNING. ESTIMATED INSTALLATION TIME: 60 TO 90 MIN.

NOTE: REMOVABLE THREAD LOCK SHOULD BE USED ON ALL HARDWARE.

Instructions:

1. Park motorcycle on level surface.
2. Using a 6mm Allen Wrench, remove the 4 bolts in the passenger handles (2 in each handle). **See Diagram 1.**
3. Once handles are removed, use an 8mm wrench to remove the two bolts that hold the back of the seat to the bike. Lift seat off.
4. Turn seat upside-down on a work surface, place Bottom Mounting Bracket (Y-shaped) on underside of seat, nesting curve of Bottom Mounting Bracket along curve of seat bottom. Attach Rubber Strip to Bottom Mounting Bracket in line with factory installed rubber rests. **See Diagram 2.**
5. Using Bottom Mounting Bracket as a template, mark locations of holes on seat base. **See Diagram 2.**
6. Remove Bottom Mounting Bracket to drill holes. Using a 9/32" bit, drill holes through white plastic seat base according to marked locations from step 5.
7. After drilling holes, flip seat right-side up. Clean the upper driver's seat-back area with rubbing alcohol and a lint free cloth.
8. Locate centerline of seat. **See Diagram 3.**
9. Mark a location on seat-back top surface approximately 3/4" to 1" in front of the stitched seam. **See Diagram 3.**
10. Align Protective Cover (Rubber gasket) and remove backing from double-sided tape to affix to seat at marked location.
11. With Protective Cover secured, use a utility knife to make a 1-1/2" wide slit in the vinyl seat covering. **See Diagram 3.**
Before proceeding, become familiar with steps 12-15 and accompanying Diagrams.
12. Using a long, serrated knife (a bread knife works well), cut down through the slit, gently cutting through the foam. Angle of the cut should be approximately parallel with the side stitching on the seat cover. The knife cut will create a guided path for the Top Mounting Bracket. **See Diagram 4.**
13. Push the knife down until it appears on the other side of the drilled holes in the seat base. Remove knife from seat.
14. Push Top Mounting Bracket down through knife cut and guide through path in seat foam until the M6 x 1.0 threaded holes in Top Mounting Bracket align with the drilled holes in seat bottom.
15. Place Bottom Mounting Bracket in same location as in step 4, aligning holes in the seat bottom with the tapped holes at the end of Top Mounting Bracket. Using a 5mm Allen Wrench, attach the Bottom Mounting Bracket to Top Mounting Bracket through seat bottom by installing (2) M6-1.0 x 25mm Socket Head Cap Screws with (2) M6 Lock Washers.
16. Using a 4mm Allen Wrench, install the Adjustment Plate to Top Mounting Bracket using (2) M6-1 x 18mm Button Head Cap Screw and (2) 6mm Lock Washers and (2) 6mm Flat Washers. Hand tighten. **See Diagram 5.**
17. Using a 1/8" Allen Wrench, attach Backrest Mounting Bracket to Backrest Pad by installing (2) 10-32 x 1/2" Button Head Cap Screws into the (2) punched holes in rear of Backrest Pad (slight pressure may be required to start screws in Backrest Pad). Tighten screws.
18. Using a 3/16" Allen Wrench and a 7/16" wrench, install the Adjustable Tongue to the Top Mounting Bracket with the Big Bike Parts stamp facing forward using (1) 1/4-20 x 3" Socket Head Cap Screw and (1) 1/4-20 Nylock Lock Nut. Hand tighten to retain adjustability.
19. Using a 3/16" Allen Wrench and a 7/16" wrench, install Adjusting Bracket to Backrest Mounting Bracket on Backrest Pad with Big Bike Parts stamp facing rear of bike using (1) 1/4-20 x 2-3/4" Socket Head Cap Screw and (1) 1/4-20 Nylock Lock Nut. Hand tighten to retain adjustability.
20. Using a 4mm Allen wrench, attach adjustable tongue to adjusting bracket at desirable height using (2) M6-1.0 x 14mm Button Head Cap Screw and (2) 6mm Lock Washers. Tighten. **Review Diagram 6.**
21. To complete backrest installation, reinstall seat by reversing steps 2 and 3.
22. Move adjustment bracket to desired position and tighten all fasteners. Double-check all work.
23. Attach pouch to the three snaps on the back of the backrest.

Diagram 1

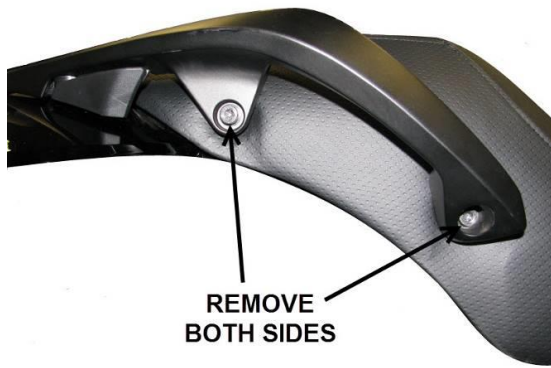

Diagram 2

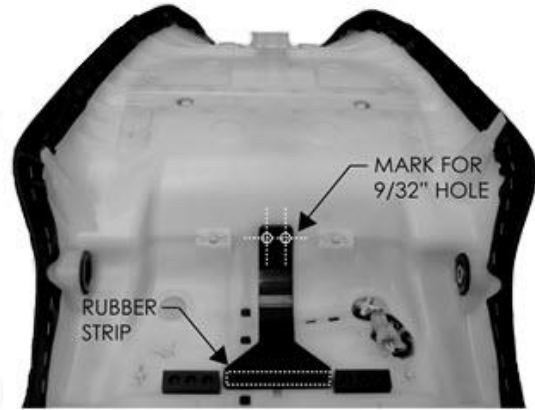

Diagram 3

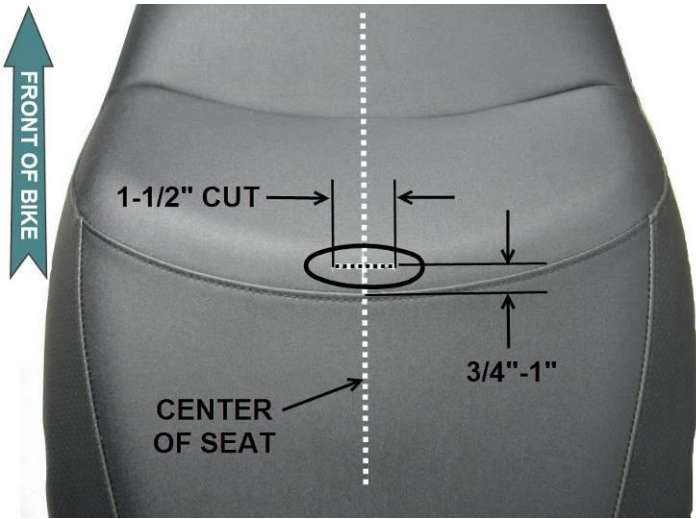

Diagram 4

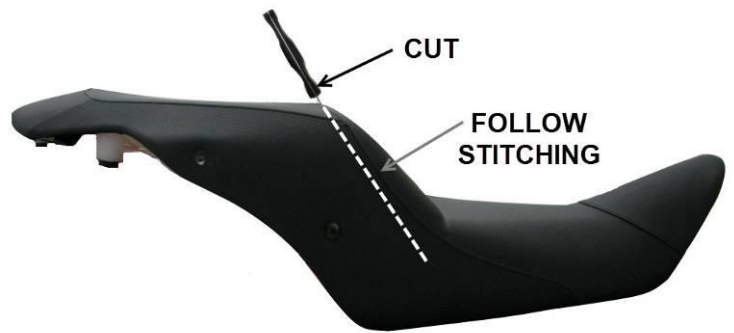

Diagram 5

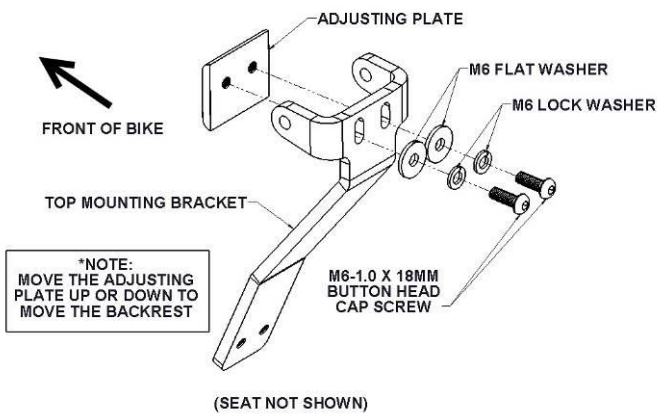
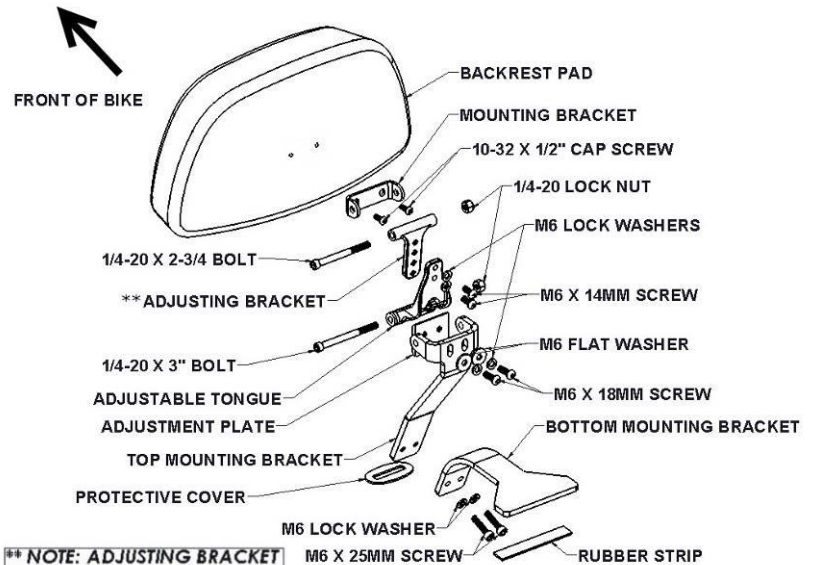

Diagram 6



**** NOTE: ADJUSTING BRACKET CAN BE MOVED TO THE OTHER SIDE OF THE ADJUSTABLE TONGUE FOR MORE SET BACK**

WARNING

BACKREST IS DESIGNED TO SUPPORT RIDERS LOWER BACK WHEN RIDING. DO NOT APPLY EXCESSIVE FORCE BY PUSHING BACK WITH YOUR FULL BODY WEIGHT. DO NOT USE BACKREST TO LIFT OR SUPPORT MOTORCYCLE.

NOTICE

IGNORING THE CONTENTS OF THESE INSTRUCTIONS MAY AFFECT THE PRODUCT PERFORMANCE AND FUNCTIONALITY. NOT FOLLOWING THESE INSTRUCTION MAY CAUSE DAMAGE TO THE PRODUCT OR THE VEHICLE TO WHICH IT IS BEING ATTACHED.