

BIG BIKE PARTS[®]

INSTALLATION INSTRUCTIONS

PART NO. 52-939A TAPERED SEAT BOLTS

1. REMOVE BOTH SIDE COVERS FROM BIKE.
2. USING A 6MM ALLEN WRENCH REMOVE THE OEM BOLTS AND WASHERS (IF EQUIPPED).
3. APPLY REMOVABLE THREAD LOCK TO THE THREADS OF THE NEW BOLTS AND INSTALL THEM AND WASHERS IN THE SAME ORDER YOU REMOVED THEM.
4. REINSTALL BOTH SIDE PANELS.

NOTICE

IGNORING THE CONTENTS OF THESE INSTRUCTIONS MAY AFFECT THE PRODUCT PERFORMANCE AND FUNCTIONALITY. NOT FOLLOWING THESE INSTRUCTION MAY CAUSE DAMAGE TO THE PRODUCT OR THE VEHICLE TO WHICH IT IS BEING ATTACHED.

NOTE: WHEN INSTALLING ON A GOLDWING BE SURE THE SPACERS AND WASHERS ARE IN PLACE WHEN INSTALLING NEW TAPERED BOLTS.

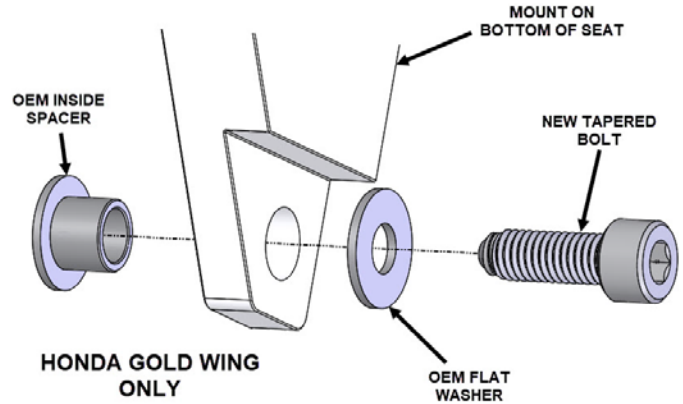

BIG BIKE PARTS[®]

INSTALLATION INSTRUCTIONS

PART NO. 52-939A TAPERED SEAT BOLTS

1. REMOVE BOTH SIDE COVERS FROM BIKE.
2. USING A 6MM ALLEN WRENCH REMOVE THE OEM BOLTS AND WASHERS (IF EQUIPPED).
3. APPLY REMOVABLE THREAD LOCK TO THE THREADS OF THE NEW BOLTS AND INSTALL THEM AND WASHERS IN THE SAME ORDER YOU REMOVED THEM.
4. REINSTALL BOTH SIDE PANELS.

NOTICE

IGNORING THE CONTENTS OF THESE INSTRUCTIONS MAY AFFECT THE PRODUCT PERFORMANCE AND FUNCTIONALITY. NOT FOLLOWING THESE INSTRUCTION MAY CAUSE DAMAGE TO THE PRODUCT OR THE VEHICLE TO WHICH IT IS BEING ATTACHED.

NOTE: WHEN INSTALLING ON A GOLDWING BE SURE THE SPACERS AND WASHERS ARE IN PLACE WHEN INSTALLING NEW TAPERED BOLTS.

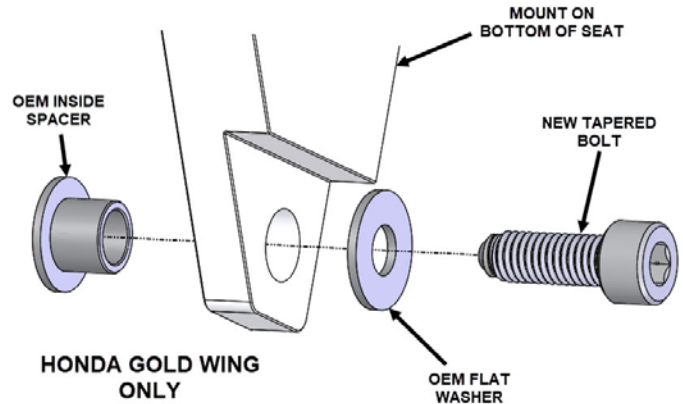

BIG BIKE PARTS[®]

INSTALLATION INSTRUCTIONS

PART NO. 52-939A TAPERED SEAT BOLTS

1. REMOVE BOTH SIDE COVERS FROM BIKE.
2. USING A 6MM ALLEN WRENCH REMOVE THE OEM BOLTS AND WASHERS (IF EQUIPPED).
3. APPLY REMOVABLE THREAD LOCK TO THE THREADS OF THE NEW BOLTS AND INSTALL THEM AND WASHERS IN THE SAME ORDER YOU REMOVED THEM.
4. REINSTALL BOTH SIDE PANELS.

NOTICE

IGNORING THE CONTENTS OF THESE INSTRUCTIONS MAY AFFECT THE PRODUCT PERFORMANCE AND FUNCTIONALITY. NOT FOLLOWING THESE INSTRUCTION MAY CAUSE DAMAGE TO THE PRODUCT OR THE VEHICLE TO WHICH IT IS BEING ATTACHED.

NOTE: WHEN INSTALLING ON A GOLDWING BE SURE THE SPACERS AND WASHERS ARE IN PLACE WHEN INSTALLING NEW TAPERED BOLTS.

