

Copyright © 2018 by Big Bike Parts, Inc. No part of this instruction sheet may be reproduced without the written permission of Big Bike Parts, Inc.

PART NO. 52-942WI

ACCESSORY SUB-HARNESS

REVISED 8/19/2020

FITMENT: HONDA GOLDWING/TOUR 2018-NEWER

TOOLS NEEDED: 6MM ALLEN WRENCH

PLEASE READ THROUGH AND UNDERSTAND THESE INSTRUCTIONS BEFORE BEGINNING. USE REMOVABLE THREAD LOCK ON ALL SCREWS.
ESTIMATED INSTALLATION TIME: 30 TO 45 MIN.

INSTALLATION:

1. OPEN BOTH SADDLEBAGS AND REMOVE THE SIDE COVER FROM EACH SIDE OF THE BIKE (FIG. 1).
2. USE A 6MM ALLEN WRENCH TO REMOVE THE TWO SEAT BOLTS (FIG. 2 SHOWS LEFT SIDE). UNPLUG THE SEAT HARNESS CONNECTOR ON THE RIGHT SIDE OF THE BIKE (FIG. 3) AND REMOVE THE SEAT BY LIFTING THE FRONT OF THE SEAT AND PULLING FORWARD TOWARDS THE FRONT OF THE BIKE.
3. LOCATE THE LEFT AND RIGHT SADDLEBAG CONNECTORS (FIG. 4) AND DISCONNECT BOTH LEFT AND RIGHT SADDLEBAG CONNECTORS.
4. USE FIG. 5 TO DETERMINE LEFT AND RIGHT ACCESSORY SUB-HARNESS PLUGS. FIG. 5 ALSO SHOWS WIRE FUNCTIONS FOR CONNECTING ACCESSORIES TO THE ACCESSORY SUB-HARNESS.
5. INSERT THE LEFT CONNECTOR FROM THE ACCESSORY SUB-HARNESS TO THE LEFT SADDLEBAG CONNECTORS AS SHOWN IN FIG. 6.
6. INSERT THE RIGHT CONNECTOR FROM THE ACCESSORY SUB-HARNESS TO THE RIGHT SADDLEBAG CONNECTORS AS SHOWN IN FIG. 6.
7. TUCK THE CONNECTORS AND WIRES DOWN AND OUT OF THE WAY SO THEY DO NOT GET PINCHED OR PULLED WHEN SEAT IS INSTALLED.
8. REASSEMBLE THE GOLDWING IN REVERSE ORDER.

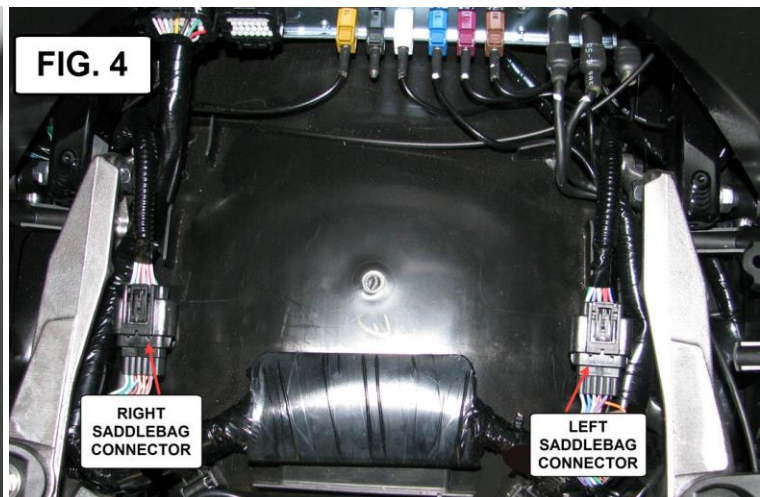
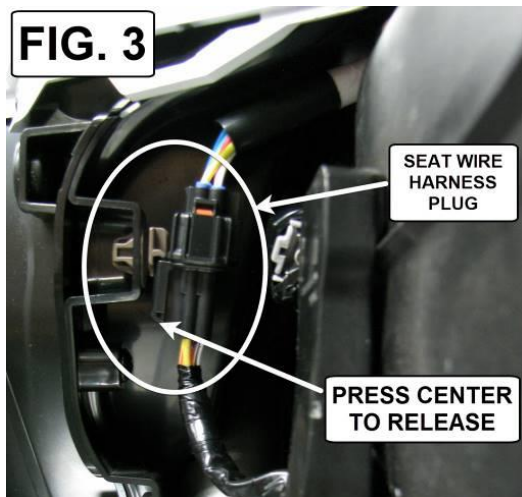
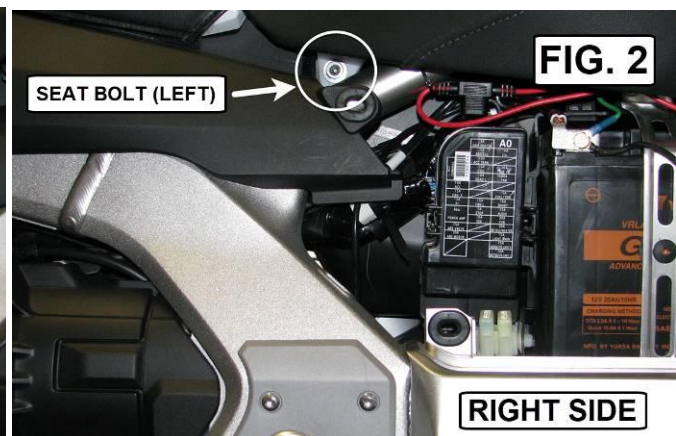
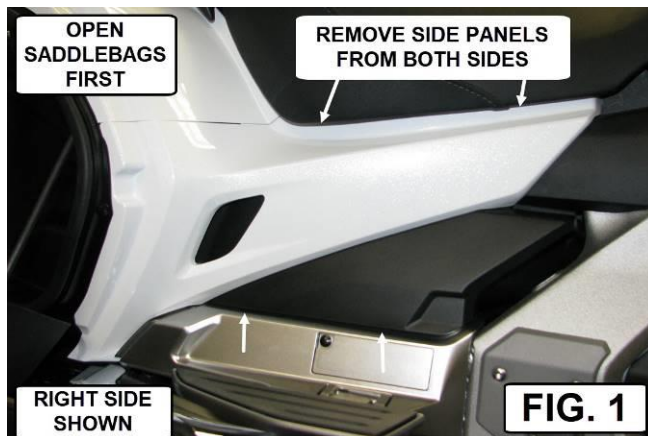
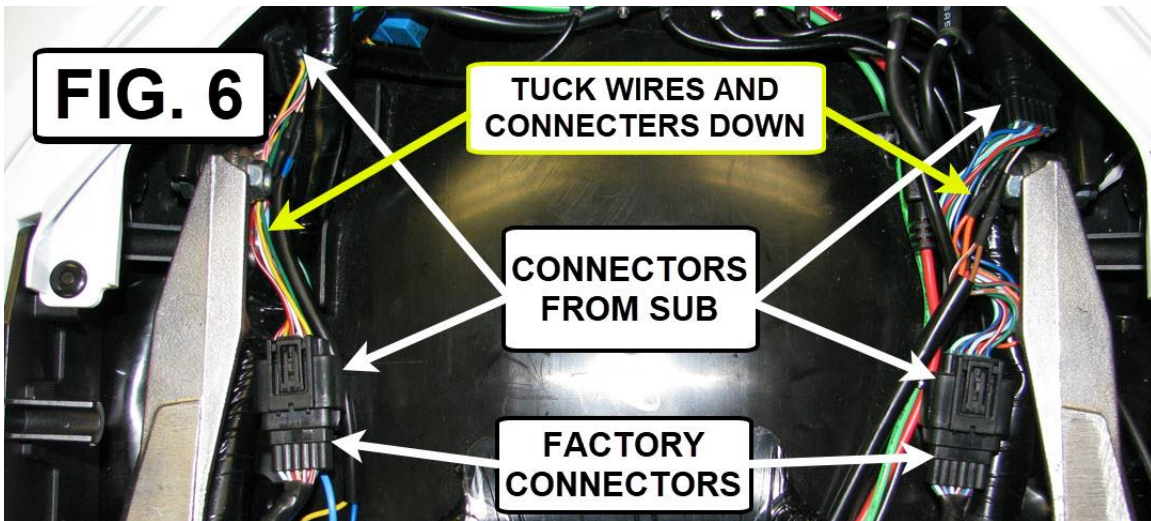
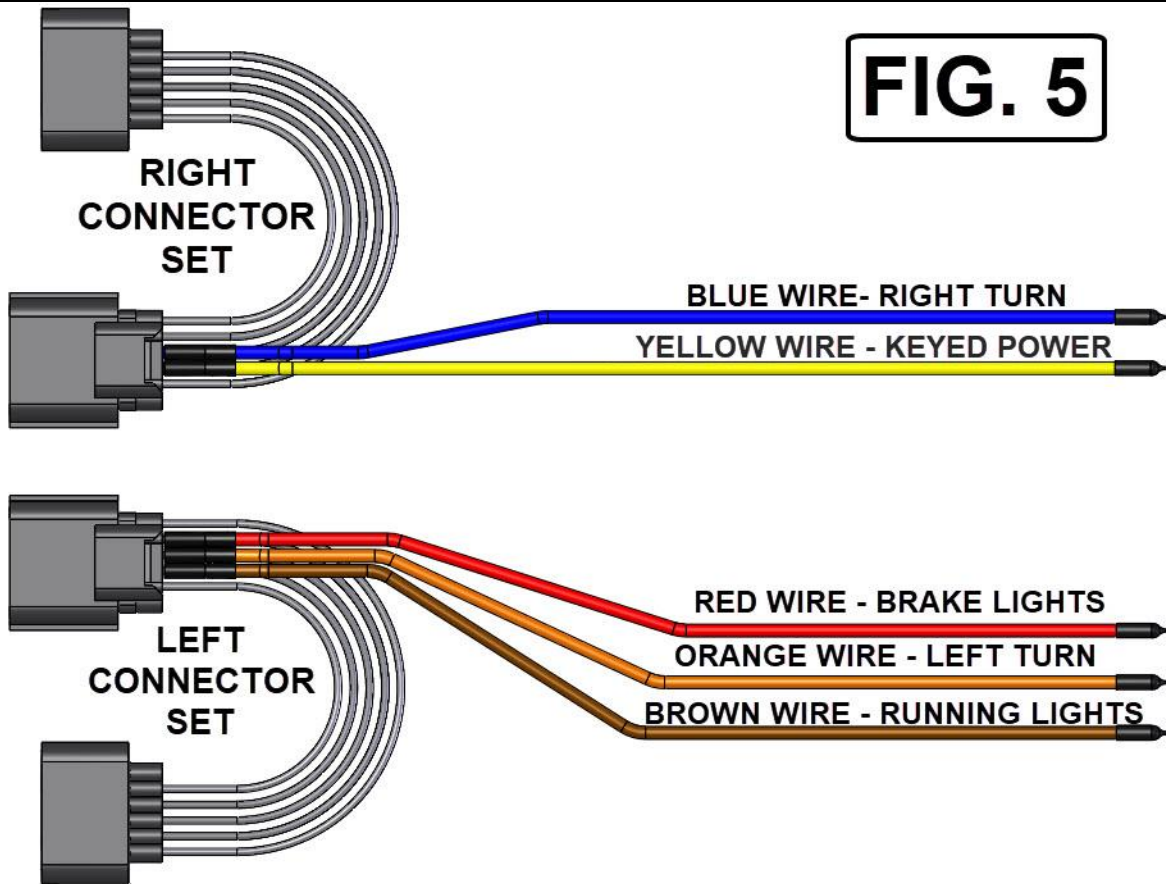

FIG. 5



NOTICE

IGNORING THE CONTENTS OF THESE INSTRUCTIONS MAY AFFECT THE PRODUCT PERFORMANCE AND FUNCTIONALITY. NOT FOLLOWING THESE INSTRUCTION MAY CAUSE DAMAGE TO THE PRODUCT OR THE VEHICLE TO WHICH IT IS BEING ATTACHED.