

BIG BIKE PARTS® INSTALLATION INSTRUCTIONS

Copyright© 2009 by Big Bike Parts, Inc. No part of this instruction sheet may be reproduced without the written permission of Big Bike Parts Inc.®

Part No. 55-145A

CELESTAR RADIATOR GRILLE
HONDA VTX1800

3/24/2010

TOOLS NEEDED: 10MM SOCKET WRENCH 5MM ALLEN WRENCH THREAD LOCKER

HARDWARE INCLUDED: (2) ANTI-VIBRATION RUBBER WITH DOUBLE SIDED TAPE (2) SPACER (BBP# W5151012PZ)
(2) M6-1.0 X 40MM SOCKET HEAD CAP SCREW (BBP# S6061040PZ)
(2) M6-1.0 X 18MM BUTTON SOCKET HEAD CAP SCREW (BBP# S5061018SS)
(4) RUBBER WASHER

NOTE: WE RECOMMEND USING THREAD LOCKER ON ALL FASTENERS.

INSTALLATION:

1. REMOVE OEM RADIATOR GRILLE FRAME BY USING 5MM ALLEN WRENCH TO REMOVE ALL BUTTON SOCKET HEAD CAPSCREWS; TWO ON TOP, TWO ON EACH SIDE, AND ONE ON BOTTOM. REMOVE OEM RADIATOR GRILLE FRAME.
2. REMOVE OEM RADIATOR GRILL LOWER SUPPORT BRACKET BY USING 10MM SOCKET WRENCH TO REMOVE TWO HEX HEAD CAP SCREWS.
3. REMOVE THREE HEX HEAD FLANGE SCREWS THAT ATTACH RADIATOR TO FRAME BY USING 10MM SOCKET WRENCH; ONE ON TOP AND TWO ON BOTTOM OF RADIATOR.
4. INSTALL THE ANTI-VIBRATION RUBBER WITH DOUBLE SIDED TAPE (A) ON BACK OF NEW BBP RADIATOR GRILLE (B) LINING UP CORRECTLY WITH THE BIKE, AS SHOWN IN FIGURE 1 BELOW. EACH ABOUT 1 INCH FROM THE EDGE AND A 1/2 INCH ABOVE THE GRILLE.

IF INSTALLING NEW BBP RADIATOR GRILLE (B) ON BIKE THAT HAS BBP HIGHWAY BARS SKIP TO STEP #6, IF NOT GO TO STEP #5.

5. INSTALL SUPPORT BRACKET WELDMENT (C) USING 10MM SOCKET WRENCH AND THE TWO SCREWS REMOVED FROM THE BOTTOM OF THE RADIATOR IN STEP #3. THE SLOTTED HOLES SHOULD BE UP AGAINST THE RUBBER ISOLATORS ON THE BOTTOM OF THE RADIATOR BRACKET AS SHOWN BELOW IN FIGURE 2. INSTALL BUT DO NOT TIGHTEN COMPLETELY.
6. IF INSTALLING OVER BBP HIGHWAY BARS, THE SUPPORT BRACKET WELDMENT (C) SHOULD BE INSTALLED WITH THE TWO SPACERS (D) AND THE TWO M6-1.0 X 40MM SOCKET HEAD CAP SCREWS (E), AS SHOWN BELOW IN FIGURE 1.
7. TEMPORARILY INSTALL THE NEW BBP RADIATOR GRILLE (B) (OVER BBP HIGHWAY BARS, IF MOUNTING GRILLE OVER BBP HIGHWAY BARS) BY ALIGNING THE TOP MOUNTING HOLE WITH THE MOUNTING HOLE ON THE TOP OF THE RADIATOR, AND THE TWO BOTTOM MOUNTING HOLES WITH THE SUPPORT BRACKET MOUNTING HOLES. REMOVE THE NEW BBP RADIATOR GRILLE (B) AND TIGHTEN THE SCREWS THAT ARE HOLDING THE SUPPORT BRACKET WELDMENT (C) FROM STEP #5 OR STEP #6.
8. INSTALL THE NEW BBP RADIATOR GRILLE, AS SHOWN BELOW IN FIGURE 1. THEN USING 10MM WRENCH, INSTALL TOP OEM M6-1.0 X 30MM LONG HEX HEAD SCREW AND WASHER, (2) M6-1.0 X 18MM LONG BUTTON SOCKET HEAD CAP SCREWS (F), AND (4) RUBBER WASHERS (G), THEN TIGHTEN ALL THREE SCREWS.

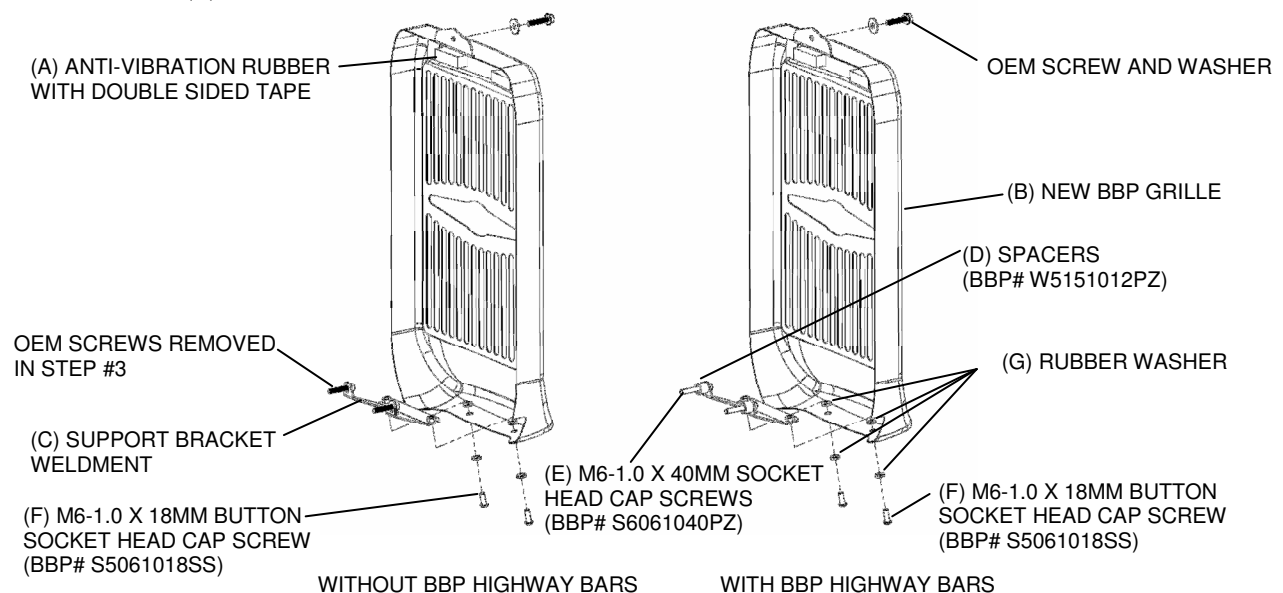

Figure 1 - PLACEMENT OF MOUNTING SCREWS AND WASHERS