

INSTALLATION INSTRUCTIONS

PART NO. 55-312/55-312L CONTOUR DRIVING LIGHT KIT
 HONDA VALKYRIE 1997-2003, VTX1300C/R/S 2003-2009, &
 VTX1800C/F/N/R/S 2002-2008

1/27/2012

TOOLS NEEDED:	#2 PHILLIPS SCREWDRIVER DRILL	13MM WRENCH 13/16" DRILL BIT THREADLOCK COMPOUND	12MM WRENCH 2MM ALLEN WRENCH	5MM ALLEN WRENCH 4MM ALLEN WRENCH	6MM ALLEN WRENCH 14MM SOCKET WRENCH
HARDWARE INCLUDED:	(3) M6-1.0 X 16MM LONG BUTTON SOCKET HEAD CAP SCREW (4) M4-0.7 X 6MM LONG CUP POINT SOCKET HEAD SET SCREW (2) M8-1.25 NYLOCK HEX NUT (2) M8 LOCK WASHER (2) M8 LOCK WASHER		(2) M4-0.7 X 3MM LONG CUP POINT SOCKET HEAD SET SCREW (2) M6-1.0 X 15MM LONG BUTTON SOCKET HEAD CAP SCREW (2) M8-1.25 X 20MM LONG SOCKET HEAD CAP SCREW (3) M6 LOCK WASHER (2) EXTENSION NUT		

NOTE: THREADLOCKER SHOULD BE USED ON ALL HARDWARE.**INSTALLATION:**

1. DISCONNECT THE NEGATIVE BATTERY CABLE.
2. USING PHILLIPS SCREWDRIVER, REMOVE THE TWO SCREWS ON THE SIDE OF THE HEADLIGHT AND REMOVE THE HEADLIGHT.
3. USING A 13MM WRENCH REMOVE THE TWO NUTS UNDER THE LOWER FORK ASSEMBLY WHICH HOLD THE OEM HEADLIGHT BRACKET. (THESE NUTS WILL NOT BE REUSED)
4. INSTALL THE TWO LONG EXTENSION NUTS (C) IN PLACE OF THE OEM NUTS AND TIGHTEN SECURELY WITH A 12MM WRENCH.
5. USING THE TWO M8 - 1.25 X 20MM LONG SOCKET HEAD CAP SCREWS AND LOCK WASHERS PROVIDED (D) ATTACH MOUNTING PLATE (E) ONTO THE EXTENSION NUTS (C) AND TIGHTEN USING 6MM ALLEN WRENCH.
6. INSTALL THE NEW SPOT LIGHTS (H) ONTO THE LIGHT BAR (G) USING LOCK NUTS AND LOCK WASHERS (J) PROVIDED WITH THE LIGHTS. POSITION THE LIGHTS. TIGHTEN WITH A 14MM SOCKET.

NOTE: STEPS 7, 8, 9, & 11 ARE FOR INSTALLING OEM TURNSIGNALS WITH PURCHASE OF 55-122T ADAPTERS.

7. TO RELOCATE THE OEM TURN SIGNALS (K) REMOVE THEM USING A 5MM ALLEN WRENCH, UNPLUG THE WIRE LEADS THAT GO INTO THE HEADLIGHT HOUSING.
8. INSTALL EACH OEM TURN SIGNAL (K) ONTO THE TURN SIGNAL ADAPTER (L) ROUTING THE WIRES THROUGH THE EXTRA HOLE IN THE ADAPTER. THEN USING THE M6 - 1.0 X 15MM LONG BUTTON SOCKET HEAD CAP SCREW (M) TIGHTEN WITH A 5MM ALLEN WRENCH.
9. ROUTE THE TURN SIGNAL WIRES AND SPOT LIGHT WIRE UNDER THE LIGHT BAR (G).
10. THE TURN SIGNAL ADAPTER (L) WITH OEM TURN SIGNAL (K) CAN BE POSITIONED INTO THE LOWER ENDS OF THE LIGHT BAR (G) AND SECURED WITH THE SET SCREWS (N) THE SHORT SET SCREWS GO IN THE BACK HOLES. THERE ARE THREE SET SCREWS ON EACH SIDE.

NOTE: THERE ARE THREE DIFFERENT SETS OF MOUNTING HOLES ON THE LIGHT BAR THIS IS FOR ADJUSTABILITY BETWEEN BIKES. CHOOSE THE ONES THAT WILL GET THE LIGHT BAR CLOSEST TO THE FORKS WITHOUT HITTING ANYTHING.

11. USING THE M6 - 1.0 X 16MM LONG BUTTON SOCKET HEAD CAP SCREWS AND LOCK WASHERS PROVIDED (F) INSTALL THE LIGHT BAR (G) ONTO THE MOUNTING PLATE (E). TIGHTEN SECURELY WITH A 4MM ALLEN WRENCH.
12. RE-ROUTE THE TURN SIGNAL WIRES INTO THE HEADLIGHT HOUSING AND RE-CONNECT AS THEY WERE.
13. LOCATE YOUR BIKE'S BATTERY, FUSE BLOCK, AND/OR ACCESSORY TERMINALS AND WIRE ACCORDING TO THE DIAGRAM ON BACK.

WIRING THE DRIVING LIGHTS (SEE DIAGRAM 2)**NOTE: IF A 13-207/52-605/52-605L SWITCH BLOCK IS PURCHASED, STEPS C, D & E CAN BE SKIPPED AND PLUG ONE OF THE SWITCHES INTO THE RELAY.**

14. CONNECT THE BLACK WIRES TO THE CONNECTORS ON EACH LIGHT. THE OTHER ENDS OF THE BLACK WIRES CONNECT TO THE RELAY AS SHOWN IN THE DIAGRAM. THE RELAY CAN BE LOCATED UNDER THE SIDE COVER OR SEAT. THE WIRES CAN BE ROUTED THROUGH THE LIGHT BAR AND UNDER THE FUEL TANK OR ALONG THE INSIDE OF THE FRAME TO KEEP THEM OUT OF SIGHT.
15. THE WIRE HARNESS WITH THE RED AND GREEN WIRES CONNECTS THE BATTERY TO THE RELAY. THIS HARNESS ALSO HAS AN INLINE FUSE ON THE RED WIRE. THE ENDS WITH THE RING TERMINALS SHOULD BE PLACED UNDER THE SCREWS THAT HOLD THE BATTERY CABLES TO THE BATTERY TERMINALS. CONNECT THE OTHER ENDS OF THE HARNESS TO THE RELAY AS SHOWN IN THE DIAGRAM.

NOTE: IF A BIG BIKE PARTS ACCESSORY SWITCH BLOCK (13-207 OR 52-605) HAS BEEN PURCHASED YOU CAN USE THIS TO CONTROL THE LIGHTS IN PLACE OF THE SWITCH THAT HAS BEEN SUPPLIED WITH THE DRIVING LIGHT KIT. FOLLOW THE WIRING INSTRUCTIONS IN THE SWITCH BLOCK KIT FOR DIRECTIONS ON CONNECTING THE SWITCH BOX TO THE RELAY AND OMIT STEPS C, D AND E BELOW.

16. FIND A CONVENIENT PLACE TO INSTALL THE SWITCH. DRILL A SMALL PILOT HOLE FIRST AND THEN DRILL IT OUT LARGER WITH A 13/16" DRILL BIT. THE SIDE COVER MAY BE A GOOD LOCATION FOR THE SWITCH.
17. THE WIRE HARNESS WITH THREE WIRES (ORANGE, BLUE, AND GREEN) CONNECTS TO THE SWITCH. THE END OF THE HARNESS WITH THE THREE PUSH ON CONNECTORS GOES TO THE TERMINALS OF THE SWITCH AS SHOWN IN THE DIAGRAM.
18. FROM THE SWITCH, THE GREEN WIRE CAN BE CONNECTED TO THE NEGATIVE TERMINAL OF THE BATTERY. THE BLUE WIRE CONNECTS TO THE RELAY AS SHOWN IN

THE DIAGRAM. THE ORANGE WIRE WILL NEED TO CONNECT TO A KEYED POWER SOURCE. A KEYED POWER SOURCE IS A WIRE THAT HAS POWER ONLY WHEN THE KEY IS IN THE "ACCESSORY" OR "ON" POSITION. WHEN A KEYED POWER SOURCE WIRE IS FOUND, CLAMP THE T-TAP CONNECTOR TO THE WIRE AND THEN CONNECT THE ORANGE WIRE TO THE T-TAP.

19. ROUTE THE BARE ENDED WIRES ON EACH LIGHT THROUGH THE LIGHT BAR AND OUT THE MIDDLE HOLE. ATTACH RING TERMINALS TO THE BARE ENDS OF THE WIRES AND THEN PLACE THEM UNDER THE M6-1.0 X 16MM MOUNTING SCREWS UNDER THE LIGHT BAR. TIGHTEN THE SCREWS SECURELY TO INSURE THAT THE LIGHTS HAVE A GOOD GROUND.
20. TEST LIGHTS FOR PROPER OPERATION BEFORE REINSTALLING ANY REMOVED SIDE COVERS, SEATS, ETC. SECURE RELAY TO KEEP FROM BOUNCING.
21. USE THE ADHESIVE WIRE HOLDER TO HOLD WIRE UNDERNEATH THE LIGHT BAR AND OUT OF SIGHT.

DIAGRAM 1

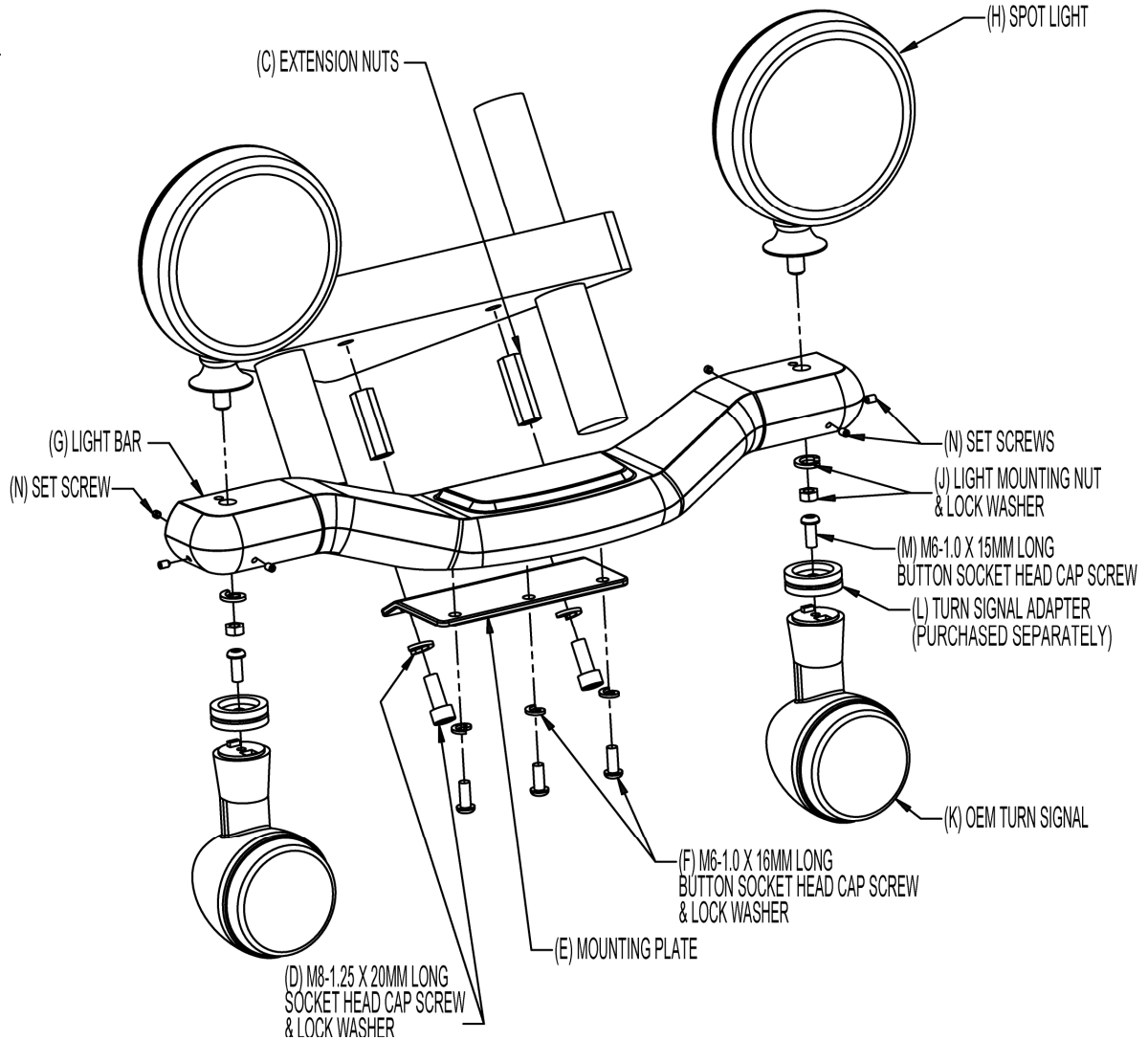

DIAGRAM 2

