

# INSTALLATION INSTRUCTIONS

PART NO. 63-613 / 63-613L

CONTOUR DRIVING KIT

YAMAHA VSTAR 1100 CLASSIC/CUSTOM

11/5/2012

<b>TOOLS NEEDED:</b>	#2 PHILLIPS SCREWDRIVER DRILL	13MM WRENCH 13/16" DRILL BIT THREADLOCK COMPOUND	12MM WRENCH 2MM ALLEN WRENCH 10MM WRENCH	8MM WRENCH 4MM ALLEN WRENCH	6MM ALLEN WRENCH 14MM SOCKET WRENCH
<b>HARDWARE INCLUDED:</b>	(3) M6-1.0 X 16MM LONG BUTTON SOCKET HEAD CAP SCREW (4) M4-0.7 X 6MM LONG CUP POINT SOCKET HEAD SET SCREW (2) M8-1.25 NYLOCK HEX NUT		(2) M4-0.7 X 3MM LONG CUP POINT SOCKET HEAD SET SCREW (3) M6 LOCK WASHER (2) M8 LOCK WASHER		

**NOTE: THREADLOCKER SHOULD BE USED ON ALL HARDWARE.****INSTALLATION:**

- DISCONNECT THE NEGATIVE BATTERY CABLE.
- USING THE PHILLIPS SCREWDRIVER, REMOVE THE TWO SCREWS HOLDING THE FRONT COVER TO THE HEADLIGHT HOUSING, AND THEN DISCONNECT THE HEADLIGHT AND SET IT ASIDE.
- DISCONNECT THE TURN SIGNALS FROM INSIDE THE HEADLIGHT HOUSING, NOTING AS TO WHICH ONE IS THE LEFT AND RIGHT TURN SIGNAL.
- REMOVE THE OEM LIGHT BAR USING A 6MM ALLEN WRENCH TO REMOVE THE TWO SOCKET HEAD CAP SCREWS HOLDING IT INTO THE FRONT OF THE TRIPLE TREE.
- REMOVE THE TURN SIGNALS FROM THE LIGHT BAR BY USING THE 8MM AND 10MM WRENCHES TO REMOVE THE NUT AND BOLT ON THE BACK OF THE TURN SIGNAL, THEN PULL THE TURN SIGNAL AND THE WIRES OUT OF THE LIGHT BAR.
- USING THE 12MM SOCKET WRENCH AND 6MM ALLEN WRENCH, REMOVE THE TWO NUTS AND BOLTS HOLDING THE HEADLIGHT BRACKET TO THE TOP OF THE TRIPLE TREE, AND SLIDE THE NEW LIGHT BAR BRACKET BETWEEN THE TOP OF THE TRIPLE TREE AND UNDER THE HEADLIGHT BRACKET. REINSTALL THE NUTS AND BOLTS JUST REMOVED AND TIGHTEN DOWN.
- INSTALL THE SPOT LIGHTS (E) ONTO THE LIGHT BAR (D) USING THE NUTS AND LOCK WASHERS (F) PROVIDED WITH THE SPOT LIGHTS. POSITION THE LIGHTS. TIGHTEN WITH A 14MM SOCKET.

**NOTE: STEPS 8,9,10, AND 12 ARE FOR INSTALLING OEM TURN SIGNALS WITH 62-112T ADAPTERS.**

- INSTALL EACH OEM TURN SIGNAL (G) ONTO THE NEW TURN SIGNAL ADAPTER (H) ROUTING THE WIRES THROUGH THE HOLE IN THE ADAPTERS. USING THE BOLTS REMOVED IN STEP 6; SECURE THE TURN SIGNAL TO THE ADAPTER.
- ROUTE THE OEM TURN SIGNAL WIRES AND SPOT LIGHT WIRE UNDER THE LIGHT BAR (D). YOU MAY HAVE TO CUT OFF OEM BULLET CONNECTORS AND ADD NEW ONES AFTER THEY ARE ROUTED.
- THE TURN SIGNAL ADAPTERS (H) WITH OEM TURN SIGNALS (G) NEED TO BE POSITIONED INTO THE LOWER ENDS OF THE NEW LIGHT BAR (D) AND SECURED WITH THE SET SCREWS (K), THE SHORT SET SCREWS GO INTO THE BACK HOLES. THERE ARE THREE SET SCREWS ON EACH SIDE.

**NOTE: THERE ARE THREE DIFFERENT SETS OF MOUNTING HOLES ON THE LIGHT BAR. THIS IS FOR ADJUSTABILITY BETWEEN BIKES. CHOOSE THE ONES THAT WILL GET THE LIGHT BAR CLOSEST TO THE FORKS WITHOUT HITTING ANYTHING.**

- USING THE M6 - 1.0 X 16MM LONG BUTTON SOCKET HEAD CAP SCREWS AND LOCK WASHERS (C), INSTALL THE LIGHT BAR (D) ONTO THE MOUNTING PLATE (A). TIGHTEN SECURELY WITH A 4MM ALLEN WRENCH.
- RE-ROUTE THE OEM TURN SIGNAL WIRES INTO THE HEADLIGHT HOUSING AND RE-CONNECT AS THEY WERE.
- LOCATE YOUR BIKE'S BATTERY, FUSE BLOCK, AND/OR ACCESSORY TERMINALS AND WIRE ACCORDING TO THE DIAGRAM ON BACK.

**WIRING THE DRIVING LIGHTS (SEE DIAGRAM 2)****NOTE: IF A 13-207/52-605L SWITCH BLOCK IS PURCHASED, STEPS C & E CAN BE SKIPPED AND PLUG ONE OF THE SWITCHES INTO THE RELAY.**

- CONNECT THE BLACK WIRES TO THE CONNECTORS ON EACH LIGHT. THE OTHER ENDS OF THE BLACK WIRES CONNECT TO THE RELAY AS SHOWN IN THE DIAGRAM. THE RELAY CAN BE LOCATED UNDER THE SIDE COVER OR SEAT. THE WIRES CAN BE ROUTED THROUGH THE LIGHT BAR AND UNDER THE FUEL TANK OR ALONG THE INSIDE OF THE FRAME TO KEEP THEM OUT OF SIGHT.
- THE WIRE HARNESS WITH THE RED AND GREEN WIRES CONNECTS THE BATTERY TO THE RELAY. THIS HARNESS ALSO HAS AN INLINE FUSE ON THE RED WIRE. THE ENDS WITH THE RING TERMINALS SHOULD BE PLACED UNDER THE SCREWS THAT HOLD THE BATTERY CABLES TO THE BATTERY TERMINALS. CONNECT THE OTHER ENDS OF THE HARNESS TO THE RELAY AS SHOWN IN THE DIAGRAM.

**NOTE: IF A BIG BIKE PARTS ACCESSORY SWITCH BLOCK (13-207 OR 52-605) HAS BEEN PURCHASED YOU CAN USE THIS TO CONTROL THE LIGHTS IN PLACE OF THE SWITCH THAT HAS BEEN SUPPLIED WITH THE DRIVING LIGHT KIT. FOLLOW THE WIRING INSTRUCTIONS IN THE SWITCH BLOCK KIT FOR DIRECTIONS ON CONNECTING THE SWITCH BOX TO THE RELAY AND OMIT STEPS C, D AND E BELOW.**

- FIND A CONVENIENT PLACE TO INSTALL THE SWITCH. DRILL A SMALL PILOT HOLE FIRST AND THEN DRILL IT OUT LARGER WITH A 13/16" DRILL BIT. THE SIDE COVER MAY BE A GOOD LOCATION FOR THE SWITCH.

- D. THE WIRE HARNESS WITH THREE WIRES (ORANGE, BLUE, AND GREEN) CONNECTS TO THE SWITCH. THE END OF THE HARNESS WITH THE THREE PUSH ON CONNECTORS GOES TO THE TERMINALS OF THE SWITCH AS SHOWN IN THE DIAGRAM.
  - E. FROM THE SWITCH, THE GREEN WIRE CAN BE CONNECTED TO THE NEGATIVE TERMINAL OF THE BATTERY. THE BLUE WIRE CONNECTS TO THE RELAY AS SHOWN IN THE DIAGRAM. THE ORANGE WIRE WILL NEED TO CONNECT TO A KEYED POWER SOURCE. A KEYED POWER SOURCE IS A WIRE THAT HAS POWER ONLY WHEN THE KEY IS IN THE "ACCESSORY" OR "ON" POSITION. WHEN A KEYED POWER SOURCE WIRE IS FOUND, CLAMP THE T-TAP CONNECTOR TO THE WIRE AND THEN CONNECT THE ORANGE WIRE TO THE T-TAP.
  - F. ROUTE THE BARE ENDED WIRES ON EACH LIGHT THROUGH THE LIGHT BAR AND OUT THE MIDDLE HOLE. ATTACH RING TERMINALS TO THE BARE ENDS OF THE WIRES AND THEN PLACE THEM UNDER THE M6-1.0 X 16MM MOUNTING SCREWS UNDER THE LIGHT BAR. TIGHTEN THE SCREWS SECURELY TO INSURE THAT THE LIGHTS HAVE A GOOD GROUND.
14. TEST LIGHTS FOR PROPER OPERATION BEFORE REINSTALLING ANY REMOVED SIDE COVERS, SEATS, ETC. SECURE RELAY TO KEEP FROM BOUNCING.

DIAGRAM 1

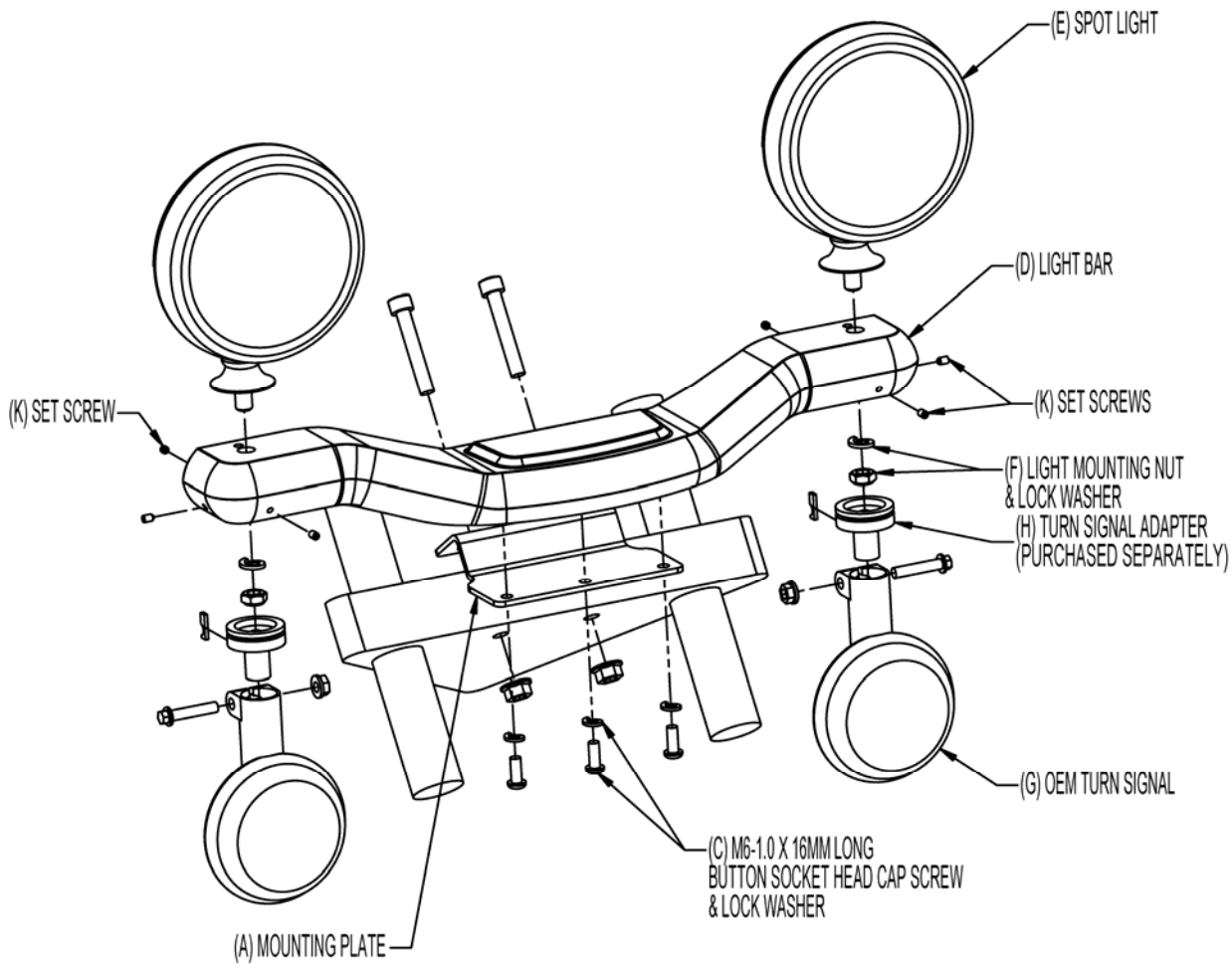
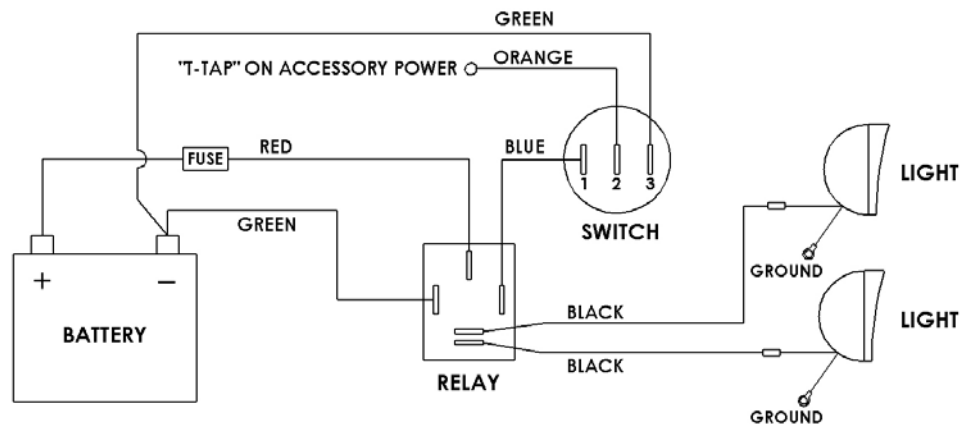

DIAGRAM 2



# INSTALLATION INSTRUCTIONS

PART NO. 63-613 / 63-613L

CONTOUR DRIVING KIT  
HONDA VT600

11/2/2012

<b>TOOLS NEEDED:</b>	#2 PHILLIPS SCREWDRIVER DRILL	13MM WRENCH 13/16" DRILL BIT THREADLOCK COMPOUND	2MM ALLEN WRENCH 10MM SOCKET WRENCH	5MM ALLEN WRENCH 4MM ALLEN WRENCH	6MM ALLEN WRENCH CLEAR SILICONE SEALANT
<b>HARDWARE INCLUDED:</b>	(3) M6-1.0 X 16MM LONG BUTTON SOCKET HEAD CAP SCREW (4) M4-0.7 X 6MM LONG CUP POINT SOCKET HEAD SET SCREW (2) M8-1.25 NYLOCK HEX NUT (2) M8 LOCK WASHER		(2) M4-0.7 X 3MM LONG CUP POINT SOCKET HEAD SET SCREW (2) M6-1.0 X 10MM LONG BUTTON SOCKET HEAD CAP SCREW (3) M6 LOCK WASHER		

**NOTE: THREADLOCKER SHOULD BE USED ON ALL HARDWARE.****INSTALLATION:**

1. DISCONNECT THE NEGATIVE BATTERY CABLE.
2. REMOVE THE NECK COVERS BY REMOVING THE SCREW AT THE TOP OF THE NECK COVERS. REMOVE THE CENTERPIECE BY PULLING IT UNTIL IT SNAPS OUT. THEN PULL OUTWARD ON BOTH NECK COVERS, GENTLY WIGGLE THE COVERS TO DISASSEMBLE THEM. THERE IS A TAB ON THE UNDERSIDE OF THE COVERS THAT WILL POP LOOSE.
3. USING A 5MM ALLEN WRENCH REMOVE THE FRONT TURN SIGNALS BY REMOVING THE BOLT AT THE BACK OF THE FORK. THEN REMOVE THE METAL COVER AND SPACER AND PULL THE TURN SIGNAL OFF THE FORK. FOLLOW THE TURN SIGNAL WIRES AND DISCONNECT THEM FROM THE BIKE. REPEAT FOR THE OTHER SIDE. BE SURE TO NOTE AS TO WHICH TURN SIGNAL IS THE LEFT AND RIGHT.

**NOTE: STEPS 4,5,6,7,8,9,11,13, 14, & 16 ARE FOR INSTALLING OEM TURN SIGNALS WITH 82-222T ADAPTERS.**

4. REMOVE THE LENS FROM THE OEM TURN SIGNALS (G) BY REMOVING THE SCREW ON THE SIDE. WITH THE LENS REMOVED, REMOVE THE BULB. THEN REMOVE THE STEEL PLATE IN THE OEM TURN SIGNAL BY REMOVING THE TWO SCREWS.
5. CUT THE BLUE AND ORANGE PLUGS OFF THE TURN SIGNAL WIRES ABOUT 1" DOWN FROM THE ENDS OF THE PLUGS. YOU MAY NEED TO ADD WIRE LENGTH LATER ON.
6. PULL THE BLACK RUBBER ADAPTER OUT OF THE OEM TURN SIGNALS (G) AND PULL THE WIRES OUT OF THE RUBBER ADAPTER. THEN REMOVE THE METAL BRACKET ON THE INSIDE OF THE TURN SIGNAL HOUSING.
7. TAKE THE TURN SIGNAL ADAPTER (H) AND PLACE AS SHOWN IN DIAGRAM 1. MAKE SURE THAT THE CENTER OF THE HOLE ON THE ADAPTER LINES UP WITH THE CENTER MARK ON THE OEM TURN SIGNAL (G) AND MARK THE CENTER OF THE HOLE WITH A FINE TIPPED MARKER. REPEAT FOR THE OTHER SIDE.
8. DRILL A 1/8" HOLE ON YOUR MARK ON THE TURN SIGNAL (G). BE CAREFUL AS TO NOT DRILL THRU BOTH SIDES OF THE TURN SIGNAL. USING A FILE REMOVE MATERIAL ON THE INSIDE OF THE HOUSING SO THE TAB ON THE ADAPTER LAYS FLAT ON THE INSIDE FACE OF THE HOUSING. REPEAT FOR THE OTHER SIDE.
9. USING A CLEAR SILICONE SEALANT LAY A SMALL BEAD AROUND THE TOP OF THE TURN SIGNALS (G). THEN PLACE THE TURN SIGNAL ADAPTERS (H) INTO PLACE AND SECURE WITH THE M6-1.0 X 10MM LONG BUTTON SOCKET HEAD CAP SCREWS (B).
10. USING THE 10MM SOCKET WRENCH REMOVE THE TWO NUTS ON THE BOTTOM OF THE TRIPLE TREE HOLDING THE HEADLIGHT BRACKET. LIFT THE HEADLIGHT BRACKET OFF FROM THE TRIPLE TREE, AND SLIDE THE MOUNTING PLATE (A) BETWEEN THE TOP OF THE TRIPLE TREE AND BENEATH THE HEADLIGHT BRACKET. REINSTALL THE NUTS JUST REMOVED AND TIGHTEN DOWN.
11. REASSEMBLE THE TURN SIGNALS IN REVERSE ORDER OF STEP 4.
12. INSTALL THE SPOT LIGHTS (E) ONTO THE LIGHT BAR (D) USING THE NUTS AND LOCK WASHERS (F) PROVIDED WITH THE SPOT LIGHTS. POSITION THE LIGHTS. TIGHTEN WITH A 14MM SOCKET.
13. ROUTE THE OEM TURN SIGNAL WIRES AND SPOT LIGHT WIRE UNDER THE LIGHT BAR (D). YOU MAY HAVE TO CUT OFF OEM BULLET CONNECTORS AND ADD NEW ONES AFTER THEY ARE ROUTED.
14. THE TURN SIGNAL ADAPTERS (H) WITH OEM TURN SIGNALS (G) NEED TO BE POSITIONED INTO THE LOWER ENDS OF THE NEW LIGHT BAR (D) AND SECURED WITH THE SET SCREWS (K), THE SHORT SET SCREWS GO INTO THE BACK HOLES. THERE ARE THREE SET SCREWS ON EACH SIDE.

**NOTE: THERE ARE THREE DIFFERENT SETS OF MOUNTING HOLES ON THE LIGHT BAR. THIS IS FOR ADJUSTABILITY BETWEEN BIKES. CHOOSE THE ONES THAT WILL GET THE LIGHT BAR CLOSEST TO THE FORKS WITHOUT HITTING ANYTHING.**

15. USING THE M6 - 1.0 X 16MM LONG BUTTON SOCKET HEAD CAP SCREWS AND LOCK WASHERS (C), INSTALL THE LIGHT BAR (D) ONTO THE MOUNTING PLATE (A). TIGHTEN SECURELY WITH A 4MM ALLEN WRENCH.
16. RE-ROUTE THE OEM TURN SIGNAL WIRES. YOU MAY HAVE TO ADD WIRE LENGTH FOR THE WIRES TO REACH. REATTACH THE CONNECTORS TO THE WIRES AND RECONNECT THE CONNECTORS TO THE BIKE.
17. LOCATE YOUR BIKE'S BATTERY, FUSE BLOCK, AND/OR ACCESSORY TERMINALS AND WIRE ACCORDING TO THE DIAGRAM ON THE BACK OF THE OTHER SHEET.

**WIRING THE DRIVING LIGHTS (SEE DIAGRAM 2)**

**NOTE: IF A 13-207/52-605L SWITCH BLOCK IS PURCHASED, STEPS C & E CAN BE SKIPPED AND PLUG ONE OF THE SWITCHES INTO THE RELAY.**

- A. CONNECT THE BLACK WIRES TO THE CONNECTORS ON EACH LIGHT. THE OTHER ENDS OF THE BLACK WIRES CONNECT TO THE RELAY AS SHOWN IN THE DIAGRAM. THE RELAY CAN BE LOCATED UNDER THE SIDE COVER OR SEAT. THE WIRES CAN BE ROUTED THROUGH THE LIGHT BAR AND UNDER THE FUEL TANK OR ALONG THE INSIDE OF THE FRAME TO KEEP THEM OUT OF SIGHT.
- B. THE WIRE HARNESS WITH THE RED AND GREEN WIRES CONNECTS THE BATTERY TO THE RELAY. THIS HARNESS ALSO HAS AN INLINE FUSE ON THE RED WIRE. THE ENDS WITH THE RING TERMINALS SHOULD BE PLACED UNDER THE SCREWS THAT HOLD THE BATTERY CABLES TO THE BATTERY TERMINALS. CONNECT THE OTHER ENDS OF THE HARNESS TO THE RELAY AS SHOWN IN THE DIAGRAM.

**NOTE: IF A BIG BIKE PARTS ACCESSORY SWITCH BLOCK (13-207 OR 52-605) HAS BEEN PURCHASED YOU CAN USE THIS TO CONTROL THE LIGHTS IN PLACE OF THE SWITCH THAT HAS BEEN SUPPLIED WITH THE DRIVING LIGHT KIT. FOLLOW THE WIRING INSTRUCTIONS IN THE SWITCH BLOCK KIT FOR DIRECTIONS ON CONNECTING THE SWITCH BOX TO THE RELAY AND OMIT STEPS C, D AND E BELOW.**

- C. FIND A CONVENIENT PLACE TO INSTALL THE SWITCH. DRILL A SMALL PILOT HOLE FIRST AND THEN DRILL IT OUT LARGER WITH A 13/16" DRILL BIT. THE SIDE COVER MAY BE A GOOD LOCATION FOR THE SWITCH.
  - D. THE WIRE HARNESS WITH THREE WIRES (ORANGE, BLUE, AND GREEN) CONNECTS TO THE SWITCH. THE END OF THE HARNESS WITH THE THREE PUSH ON CONNECTORS GOES TO THE TERMINALS OF THE SWITCH AS SHOWN IN THE DIAGRAM.
  - E. FROM THE SWITCH, THE GREEN WIRE CAN BE CONNECTED TO THE NEGATIVE TERMINAL OF THE BATTERY. THE BLUE WIRE CONNECTS TO THE RELAY AS SHOWN IN THE DIAGRAM. THE ORANGE WIRE WILL NEED TO CONNECT TO A KEYED POWER SOURCE. A KEYED POWER SOURCE IS A WIRE THAT HAS POWER ONLY WHEN THE KEY IS IN THE "ACCESSORY" OR "ON" POSITION. WHEN A KEYED POWER SOURCE WIRE IS FOUND, CLAMP THE T-TAP CONNECTOR TO THE WIRE AND THEN CONNECT THE ORANGE WIRE TO THE T-TAP.
  - F. ROUTE THE BARE ENDED WIRES ON EACH LIGHT THROUGH THE LIGHT BAR AND OUT THE MIDDLE HOLE. ATTACH RING TERMINALS TO THE BARE ENDS OF THE WIRES AND THEN PLACE THEM UNDER THE M6-1.0 X 16MM MOUNTING SCREWS UNDER THE LIGHT BAR. TIGHTEN THE SCREWS SECURELY TO INSURE THAT THE LIGHTS HAVE A GOOD GROUND.
18. TEST LIGHTS FOR PROPER OPERATION BEFORE REINSTALLING ANY REMOVED SIDE COVERS, SEATS, ETC. SECURE RELAY TO KEEP FROM BOUNCING.
19. REINSTALL THE NECK COVERS BACK ON THE BIKE IN THE REVERSE ORDER OF REMOVAL.
20. USE THE ADHESIVE WIRE HOLDER TO HOLD THE WIRES UNDERNEATH THE LIGHT BAR AND OUT OF SIGHT.

