

TOOLS NEEDED: PHILLIPS SCREWDRIVER  
8MM WRENCH  
12MM SOCKET WRENCH

14MM SOCKET WRENCH  
4MM ALLEN WRENCH  
THREAD LOCKER

10MM WRENCH  
2MM ALLEN WRENCH  
DRILL

6MM ALLEN WRENCH  
5MM ALLEN WRENCH  
13/16" DRILL BIT

**NOTE: THREAD LOCKER SHOULD BE USED ON ALL HARDWARE.**

### INSTALLATION:

1. DISCONNECT THE NEGATIVE BATTERY CABLE.
2. USING THE PHILLIPS SCREWDRIVER, REMOVE THE TWO SCREWS HOLDING THE FRONT COVER TO THE HEADLIGHT HOUSING, AND THEN DISCONNECT THE HEADLIGHT AND SET IT ASIDE.
3. DISCONNECT THE TURN SIGNALS FROM INSIDE THE HEADLIGHT HOUSING, NOTING AS TO WHICH ONE IS THE LEFT AND RIGHT TURN SIGNAL.
4. REMOVE THE OEM LIGHT BAR USING A 6MM ALLEN WRENCH TO REMOVE THE TWO SOCKET HEAD CAP SCREWS HOLDING IT INTO THE FRONT OF THE TRIPLE TREE.
5. REMOVE THE TURN SIGNALS FROM THE LIGHT BAR BY USING THE 8MM AND 10MM WRENCHES TO REMOVE THE NUT AND BOLT ON THE BACK OF THE TURN SIGNAL, THEN PULL THE TURN SIGNAL AND THE WIRES OUT OF THE LIGHT BAR.
6. USING THE 12MM SOCKET WRENCH AND 6MM ALLEN WRENCH, REMOVE THE TWO NUTS AND BOLTS HOLDING THE HEADLIGHT BRACKET TO THE TOP OF THE TRIPLE TREE, AND SLIDE THE NEW LIGHT BAR BRACKET BETWEEN THE TOP OF THE TRIPLE TREE AND UNDER THE HEADLIGHT BRACKET. REINSTALL THE NUTS AND BOLTS JUST REMOVED AND TIGHTEN DOWN.
7. INSTALL THE NEW SPOT LIGHTS (E) ON TO THE LIGHT BAR (D) USING THE THREADED STEM (L) AND LOCK NUTS (F) PROVIDED WITH THE LIGHTS. POSITION THE LIGHTS. TIGHTEN WITH A 14MM SOCKET. (CONNECT THE GROUND WIRE WITH THE RING TERMINAL TO THE M6 - 1.0 X 20MM LONG (M) SOCKET HEAD CAP SCREW AND THE POSITIVE WIRE WITH BULLET CONNECTOR WILL GO INTO THE EXTRA HOLE ON TOP OF THE LIGHT BAR. YOU WILL HAVE TO REMOVE THE BULLET CONNECTOR TO FIT INTO HOLE.)

**NOTE: STEPS 8,9,10, AND 12 ARE FOR INSTALLING OEM TURN SIGNALS WITH 62-112T ADAPTERS.**

8. INSTALL EACH OEM TURN SIGNAL (G) ONTO THE NEW TURN SIGNAL ADAPTER (H) ROUTING THE WIRES THROUGH THE HOLE IN THE ADAPTERS. USING THE BOLTS REMOVED IN STEP 6, SECURE THE TURN SIGNAL TO THE ADAPTER.
9. ROUTE THE OEM TURN SIGNAL WIRES AND MINI LIGHT WIRE INTO THE LIGHT BAR (D). YOU MAY HAVE TO CUT OFF OEM BULLET CONNECTORS AND ADD NEW ONES AFTER THEY ARE ROUTED.
10. THE TURN SIGNAL ADAPTERS (H) WITH OEM TURN SIGNALS (G) NEED TO BE POSITIONED INTO THE LOWER ENDS OF THE NEW LIGHT BAR (D) AND SECURED WITH THE SET SCREWS (K). THERE ARE THREE SET SCREWS ON EACH SIDE.
11. USING THE M6 - 1.0 X 16MM LONG BUTTON SOCKET HEAD CAP SCREWS AND LOCK WASHERS (C), INSTALL THE LIGHT BAR (D) ONTO THE MOUNTING PLATE (A). TIGHTEN SECURELY WITH A 4MM ALLEN WRENCH.
12. RE-ROUTE THE OEM TURN SIGNAL WIRES INTO THE HEADLIGHT HOUSING AND RE-CONNECT AS THEY WERE.
13. LOCATE YOUR BIKE'S BATTERY, FUSE BLOCK, AND/OR ACCESSORY TERMINALS AND WIRE ACCORDING TO THE DIAGRAM ON BACK.

**NOTE: IF A 13-207 SWITCH BLOCK IS PURCHASED, STEPS C & E CAN BE SKIPPED AND PLUG ONE OF THE SWITCHES INTO THE RELAY.**

- A) CONNECT THE BULLET CONNECTORS ON BLACK WIRES TO BULLET CONNECTORS ON LIGHT.
- B) WIRE SMALL GREEN AND RED HARNESS WITH IN-LINE FUSE DIRECTLY TO THE BATTERY: RED (+) POSITIVE, GREEN (-) NEGATIVE.
- C) FIND A CONVENIENT PLACE TO INSTALL THE SWITCH. DRILL A PILOT HOLE FIRST AND THEN DRILL A 13/16" HOLE. (CAN BE INSTALLED IN SIDE COVER.)
- D) ROUTE WIRE HARNESS, AND PLUG THE THREE SPADE CONNECTORS TO SWITCH PER DIAGRAM: (GREEN=GROUND: ORANGE=SUPPLY: BLUE=LEAD.)
- E) CONNECT THE RING TERMINAL TO THE BATTERY GROUND AND SPLICE THE T-TAP INTO A KEYED POWER SOURCE AND CONNECT THE MALE SPADE.
- F) CONNECT THE REMAINING FIVE LEADS (2 BLACK, 1 RED, 1 BLUE, AND 1 GREEN) TO THE RELAY PROVIDED AS PER DIAGRAM.

14. TEST LIGHTS FOR PROPER OPERATION BEFORE REINSTALLING ANY REMOVED SIDE COVERS, SEATS, ETC. SECURE RELAY TO KEEP FROM BOUNCING.

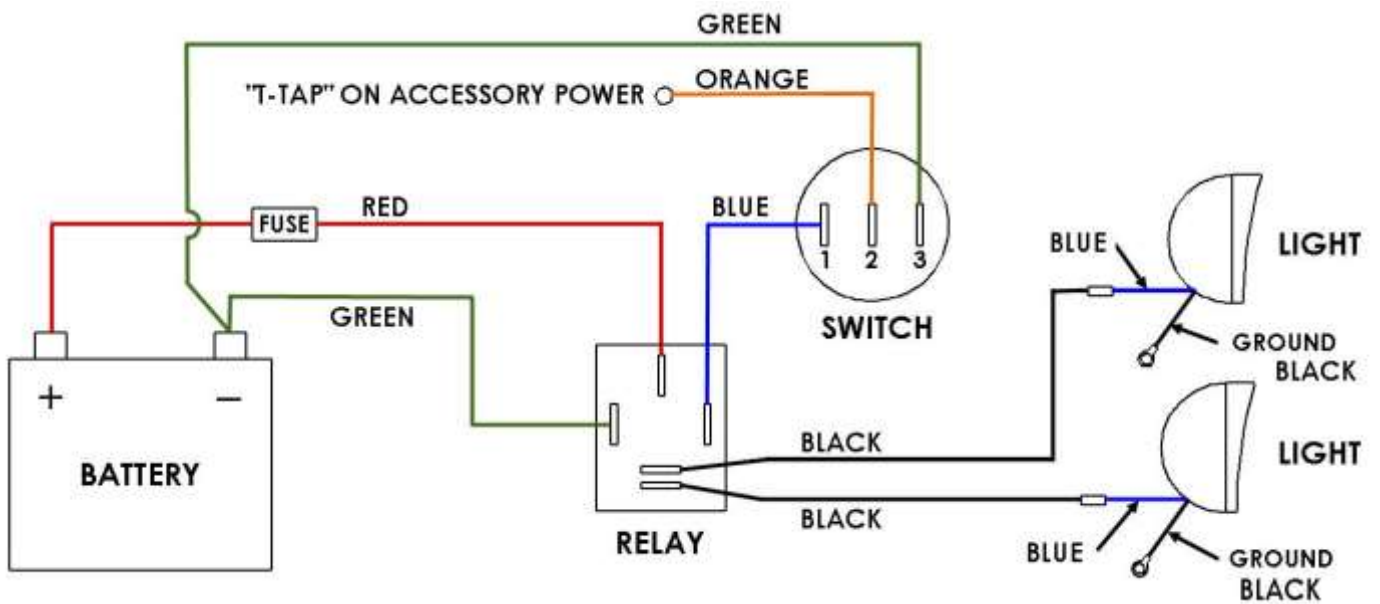
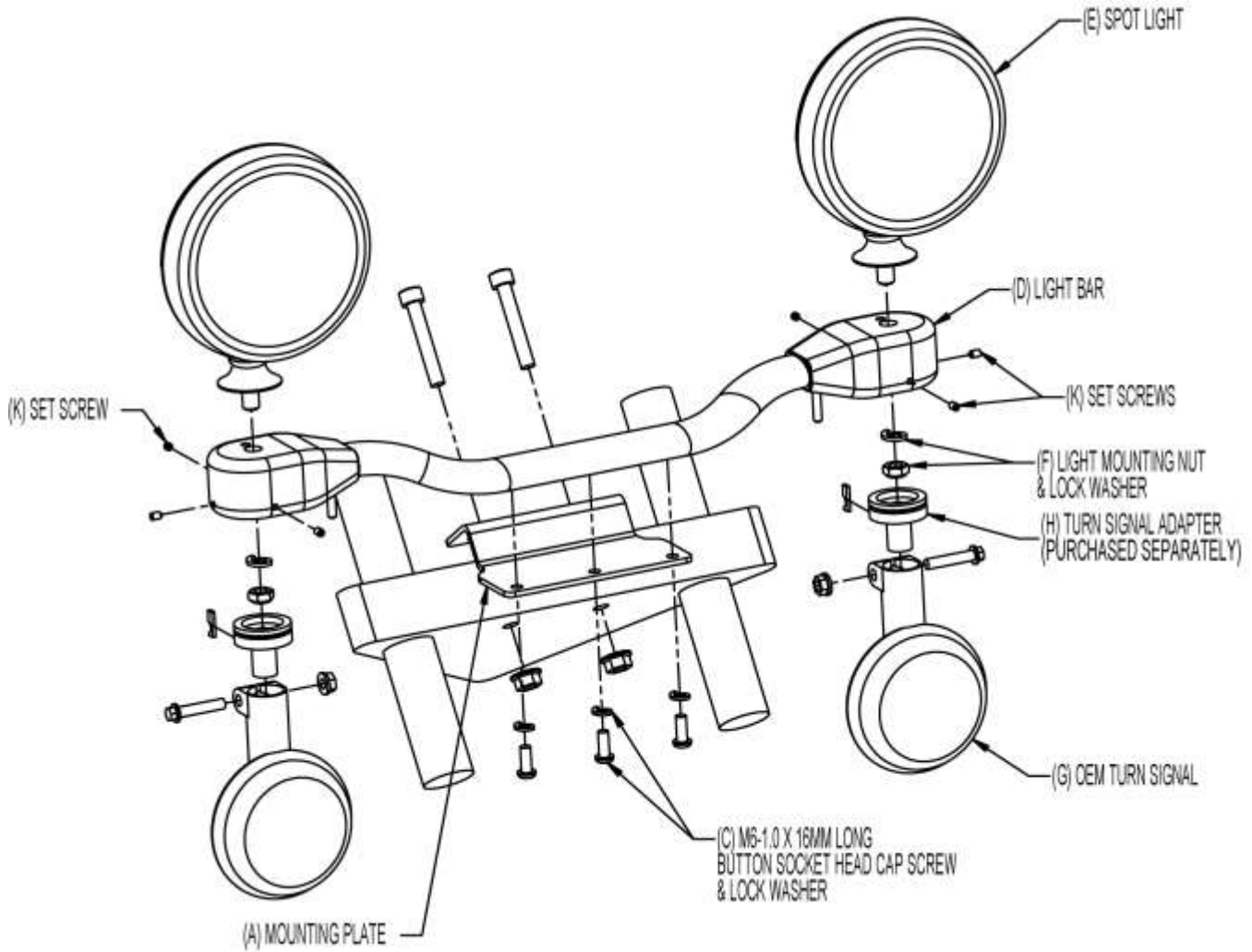

Revised 01/03/17

TOOLS NEEDED:	PHILLIPS SCREWDRIVER	14MM SOCKET WRENCH	DRILL	10MM SOCKET WRENCH	FILE
	4MM ALLEN WRENCH	5MM ALLEN WRENCH	1/4" BIT	2MM ALLEN WRENCH	THREAD LOCKER
	CLEAR SILICONE SEALANT	10MM WRENCH	3/16" BIT	FINE TIPPED MARKER	

**NOTE: THREAD LOCKER SHOULD BE USED ON ALL HARDWARE.**

## INSTALLATION:

1. DISCONNECT THE NEGATIVE BATTERY CABLE.
2. REMOVE THE NECK COVERS BY REMOVING THE SCREW AT THE TOP OF THE NECK COVERS. REMOVE THE CENTERPIECE BY PULLING IT UNTIL IT SNAPS OUT. THEN PULL OUTWARD ON BOTH NECK COVERS, GENTLY WIGGLE THE COVERS TO DISASSEMBLE THEM. THERE IS A TAB ON THE UNDERSIDE OF THE COVERS THAT WILL POP LOOSE.
3. USING A 5MM ALLEN WRENCH REMOVE THE FRONT TURN SIGNALS BY REMOVING THE BOLT AT THE BACK OF THE FORK. THEN REMOVE THE METAL COVER AND SPACER AND PULL THE TURN SIGNAL OFF THE FORK. FOLLOW THE TURN SIGNAL WIRES AND DISCONNECT THEM FROM THE BIKE. REPEAT FOR THE OTHER SIDE. BE SURE TO NOTE AS TO WHICH TURN SIGNALS IS THE LEFT AND RIGHT.

**NOTE: STEPS 4, 5, 6, 7, 8, 9, 11, 13, 14, & 16 ARE FOR INSTALLING OEM TURN SIGNALS WITH 82-222T ADAPTERS.**

4. REMOVE THE LENS FROM THE OEM TURN SIGNALS (G) BY REMOVING THE SCREW ON THE SIDE. WITH THE LENS REMOVED, REMOVE THE BULB. THEN POP THE PLATE LOOSE IN THE OEM TURN SIGNAL BY REMOVING THE TWO SCREWS.
5. CUT THE BLUE AND ORANGE PLUGS OFF THE TURN SIGNAL WIRES ABOUT 1" DOWN FROM THE ENDS OF THE PLUGS. YOU MAY NEED TO ADD WIRE LENGTH LATER ON.
6. PULL THE BLACK RUBBER ADAPTER OUT OF THE OEM TURN SIGNAL (G) AND PULL THE WIRES OUT OF THE RUBBER ADAPTER. THEN REMOVE THE METAL BRACKET ON THE INSIDE OF THE TURN SIGNAL HOUSING.
7. TAKE THE TURN SIGNAL ADAPTER (H) AND PLACE AS SHOWN IN DIAGRAM 1. MAKE SURE THAT THE CENTER OF THE HOLE ON THE ADAPTER LINES UP WITH THE CENTER MARK ON THE OEM TURN SIGNAL (G) AND MARK THE CENTER OF THE HOLE WITH A FINE TIPPED MARKER.
8. DRILL A 1/4" HOLE ON YOUR MARK ON THE TURN SIGNAL (G). BE CAREFUL AS TO NOT DRILL THRU BOTH SIDES OF THE TURN SIGNAL. USING A FILE REMOVE MATERIAL ON THE INSIDE OF THE HOUSING SO THE TAB ON THE ADAPTER LAYS FLAT ON THE INSIDE FACE OF THE HOUSING.
9. USING A CLEAR SILICONE SEALANT LAY A SMALL BEAD AROUND THE TOP OF THE TURN SIGNAL (G). THEN PLACE THE TURN SIGNAL ADAPTER (H) INTO PLACE AND SECURE WITH THE M6-1.0 X 10MM LONG BUTTON SOCKET HEAD CAP SCREW (B).
10. USING THE 10MM SOCKET WRENCH REMOVE THE TWO NUTS ON THE BOTTOM OF THE TRIPLE TREE HOLDING THE HEADLIGHT BRACKET. LIFT THE HEADLIGHT BRACKET OFF FROM THE TRIPLE TREE, AND SLIDE THE MOUNTING PLATE (A) BETWEEN THE TOP OF THE TRIPLE TREE AND BENEATH THE HEADLIGHT BRACKET. REINSTALL THE NUTS JUST REMOVED AND TIGHTEN DOWN.
11. REASSEMBLE THE TURN SIGNALS IN REVERSE ORDER OF STEP 4.
12. INSTALL THE NEW SPOT LIGHTS (E) ON TO THE LIGHT BAR (D) USING THE THREADED STEM (L) AND LOCK NUTS (F) PROVIDED WITH THE LIGHTS. POSITION THE LIGHTS. TIGHTEN WITH A 14MM SOCKET. (CONNECT THE GROUND WIRE WITH THE RING TERMINAL TO THE M6 - 1.0 X 20MM LONG (M) SOCKET HEAD CAP SCREW AND THE POSITIVE WIRE WITH BULLET CONNECTOR WILL GO INTO THE EXTRA HOLE ON TOP OF THE LIGHT BAR. YOU WILL HAVE TO REMOVE THE BULLET CONNECTOR TO FIT INTO HOLE.)
13. ROUTE THE OEM TURN SIGNAL WIRES AND SPOT LIGHT WIRE INTO THE LIGHT BAR (D). YOU MAY HAVE TO CUT OFF OEM BULLET CONNECTORS AND ADD NEW ONES AFTER THEY ARE ROUTED.
14. THE TURN SIGNAL ADAPTERS (H) WITH OEM TURN SIGNALS (G) NEED TO BE POSITIONED INTO THE LOWER ENDS OF THE NEW LIGHT BAR (D) AND SECURED WITH THE SET SCREWS (K). THERE ARE THREE SET SCREWS ON EACH SIDE.
15. USING THE M6 - 1.0 X 16MM LONG BUTTON SOCKET HEAD CAP SCREWS AND LOCK WASHERS (C), INSTALL THE LIGHT BAR (D) ONTO THE MOUNTING PLATE (A). TIGHTEN SECURELY WITH A 4MM ALLEN WRENCH.
16. RE-ROUTE THE OEM TURN SIGNAL WIRES. YOU MAY HAVE TO ADD WIRE LENGTH FOR THE WIRES TO REACH. REATTACH THE CONNECTORS TO THE WIRES AND RECONNECT THE CONNECTORS TO THE BIKE.

17. LOCATE YOUR BIKE'S BATTERY, FUSE BLOCK, AND/OR ACCESSORY TERMINALS AND WIRE ACCORDING TO THE DIAGRAM ON THE BACK OF THE OTHER SHEET.

**NOTE: IF A 13-207 SWITCH BLOCK IS PURCHASED, STEPS C & E CAN BE SKIPPED AND PLUG ONE OF THE SWITCHES INTO THE RELAY.**

- A) CONNECT THE BULLET CONNECTORS ON BLACK WIRES TO BULLET CONNECTORS ON LIGHT.
- B) WIRE SMALL GREEN AND RED HARNESS WITH IN-LINE FUSE DIRECTLY TO THE BATTERY: RED (+) POSITIVE, GREEN (-) NEGATIVE.
- C) FIND A CONVENIENT PLACE TO INSTALL THE SWITCH. DRILL A PILOT HOLE FIRST AND THEN DRILL A 13/16" HOLE. (CAN BE INSTALLED IN SIDE COVER.)
- D) ROUTE WIRE HARNESS, AND PLUG THE THREE SPADE CONNECTORS TO SWITCH PER DIAGRAM: (GREEN=GROUND: ORANGE=SUPPLY: BLUE=LEAD.)
- E) CONNECT THE RING TERMINAL TO THE BATTERY GROUND AND SPLICE THE T-TAP INTO A KEYED POWER SOURCE AND CONNECT THE MALE SPADE.
- F) CONNECT THE REMAINING FIVE LEADS (2 BLACK, 1 RED, 1 BLUE, AND 1 GREEN) TO THE RELAY PROVIDED AS PER DIAGRAM.

18. TEST LIGHTS FOR PROPER OPERATION BEFORE REINSTALLING ANY REMOVED SIDE COVERS, SEATS, ETC. SECURE RELAY TO KEEP FROM BOUNCING.

19. REINSTALL THE NECK COVERS BACK ON THE BIKE IN THE REVERSE ORDER OF REMOVAL.

